



# AGRICULTURAL PRODUCT

## Catalogue

Edition 4



**B-BBEE 2**  
EMPOWERING SUPPLIER

ISO 9001	Certified
ISO 14001	Certified
ISO 45001	Certified

# ABOUT US

Established in 1974 as a single bearing shop in Durban, South Africa; BMG's aggressive growth strategy has included acquisitions, supplemented by a steady organic growth discipline. BMG attracts best-of-breed talent resulting in technical expertise that differentiates BMG in the industry. Staff are truly part of the BMG family and its success.

BMG boasts an accredited in-house technical and commercial training academy which fosters a culture of staff development and career advancement; it's all about sustainability.

The net result, is a company that reliably supplies and supports 70 000 customers in 9 countries with the widest range of industrial engineered products and expert services in Africa via 88 branches.

BMG is positioned to deliver bespoke 360 degree solutions to its customers, and subsequently return on investment to its investors and shareholders. BMG plays a pivotal role in supporting the productivity and production targets of all Industrial, Manufacturing, Mining and Agricultural sectors of the economies in the countries it serves. With an enviable reputation as Africa's largest distributor, manufacturer and service provider of the highest quality engineering consumables and components; including

- Bearings & Seals
- Power Transmission Components
- Drives, Motors and Controllers
- Hydraulics, Pneumatics and Filtration
- Heavy and Light Duty Materials Handling
- Valves and Lubrication
- Fasteners, Gaskets and Tools

BMG is a level 2 BEE contributor with ISO 9001 Quality Assurance certification. Health and safety of its employees and customers is a paramount focus and the company adheres to ISO 45001. BMG is also committed to environmental care and sustainability and strictly follows the ISO 14001 charter.

As a key contributor to the Invicta Holdings stable, BMG has played a major part in Invicta's unique achievement of being rated in South Africa's Top 100 Companies for 21 consecutive years.



# BTC PTO'S (AFTAKAS)

## CONTENTS

Order Codes	8-9
What PTO to Use	10
Power Ratings	11
Use, Safety, Storage & Lubrication	12
General Regulations	13-16
Cross Journals	17
Steel Tubing Triangular	18
Steel Tubing Lemon & Steel Tubing Star	19
Spline Shafting	20
Tube Yokes Triangular	21
Tube Yokes Lemon	22
Tube Yokes Star	23
Quick Release Yokes	24
Interfering Bolt Yokes 6 Spline	25
Non-Interfering Bolt Yokes	26
Plain Metric / Imperial Bore Yokes	27
Hex Clamp Bolt Yokes	28
Solid Bore Yokes	28
Guard Components	29
Quick Release Pins	30
Friction Clutches (old type)	31
Overrun Clutches	32
Shearbolt Clutches	32
Friction Clutch Replacement Parts (old type)	33
Problem Solving	34-36
Quick Reference Guide	37-38



When ordering a PTO the following guide will help you to order the correct PTO:

**Examples of required PTO's, codes and explanation:**

1. Triangular profile, 6 series shaft, 1m total length, with quick release yokes on both ends and a guard.
2. Triangular profile, 6 series shaft, 1.2m total length, with tractor yoke and 30mm bore end yoke - no guard.
3. Lemon profile, 6 series shaft, 1.2m total length, with one 40mm plain metric bore yoke with keyway and threaded hole.
4. Star profile, 6 series shaft, 1.5m total length, with friction clutch.

**1. AFTB610SZ**

AFT = AFTAKAS

B = TRIANGULAR STEEL TUBING

6 = SERIES HEAVY DUTY

10 = TOTAL COMPRESSED LENGTH (IN METERS) END YOKE TO END YOKE

S = GUARD COVER ON (WITHOUT S - NO COVER ON SHAFT)

Z = TWO 6 SPLINED END YOKES (TRACTOR YOKES) AFT6.05.07

**2. AFTB612S.05.30**

AFT = AFTAKAS

B = TRIANGULAR STEEL TUBING

6 = SERIES HEAVY DUTY

12 = TOTAL COMPRESSED LENGTH (IN METERS) END YOKE TO END YOKE

S = GUARD COVER ON

05.30 = 30mm BORE PITCH BOLT (END YOKE) AFT 6.05.30 AND AFT6.05.07 ON SIDES

**3. AFTL610S.02.40**

AFT = AFTAKAS

L = LEMON STEEL TUBING

6 = SERIES HEAVY DUTY

10 = TOTAL COMPRESSED LENGTH (IN METERS) END YOKE TO END YOKE

S = GUARD COVER ON

02.40 = 40mm PLAIN BORE YOKE WITH KEYWAY AND THREADED HOLE (END YOKE) AFT6.02.40 AND AFT6.05.07 ON SIDES

BY STATING ONLY THE 02.40 YOKE, THE PTO WILL AUTOMATICALLY HAVE A AFT6.05.07 SPLINED END YOKE ON THE OPPOSITE SIDE.

#### 4. AFTS615SFFN

AFT = AFTAKAS

S = STAR PROFILE TUBING

6 = SERIES

1.5 = TOTAL COMPRESSED LENGTH (IN METERS) END YOKE TO CLUTCH

S = GUARD ON COVER

FFN = FRICTION CLUTCH AFT6.FF2 NEW AND AFT6.05.07 ON SIDES

By stating only the friction clutch, the PTO will automatically have a 6 splined end yoke on the opposite side. Due to 2 size clutches in the field, they must be identified by the following: FF - Old Type & FFN - New Type.

If the above information in the examples is not given, the following information can be used to determine the type and length of PTO required.

NB: If you are just given the steel tubing lengths, first find out what series they are and then add 400mm onto the length of the tubing to get the correct compressed length of the PTO. This however, does not apply to the 1 series, where you add 300mm. Once this is determined you can proceed with question 4 below.

#### ASK THE FOLLOWING

1. What is the H.P or kW size of the gearbox to be driven?
2. What is the rotation speed of the tractor's output shaft?
3. What is the working distance i.e. distance between tractor output shaft and gearbox input shaft?
4. What type of input shaft does the gearbox and tractor have? Eg. 6 splined or round and if so, what is the diameter?

Once this information has been determined, formulate the PTO as follows:

1. Gearbox H.P and speed, check "power ratings" eg. at 540rpm you drive a 60hp gearbox, you will need a 6 series PTO.
2. Working distance is 1.5m: PTO will be 1.5m long end yoke to end yoke.
3. Tractor output shaft 35mm 6 spline and gearbox has a 38mm round input shaft.

This will give you the following PTO:

#### B/L615S.05.38

B = Triangular tubing

L = Lemon profile tubing

The profile of the steel tubing will depend on the requirement of the client.

# WHAT PTO TO USE

## WHAT PTO TO USE ON A SLASHER (BOSSIEKAPPER)

If presented with the question: "What PTO to use on a slasher?" and the client cannot give the gearbox rating, the following will guide you supplying the correct PTO:

Determine the total width of the slasher -

Examples taken with gearbox rotation speed as 540rpm:

SLASHER WIDTH	GEARBOX SIZE			RECOMMENDED PTO
	MODE	kW RANGE	SPEED	
1.2m	AFTGBG30	24	540	AFTB412SFF
1.5m	AFTGBG61	45	540	AFTB612SFF
1.8m<	AFTGBG81	60	540	AFTB612SFF4 / B812SFF

On the 1.8m slasher, a 6 series PTO could be used provided that the use of a four (4) plate clutch is incorporated. Failing to use a four plate clutch will cause the clutch to prematurely slip (due to high load), causing unnecessary expenses and down time on the machine.

## PART NUMBER: AFT UNI SLASHER BLADE



**NOTE:** Made to order

SHAFT SIZE	540rpm			1000rpm		
	POWER		TORQUE	POWER		TORQUE
	kW	hp	N/m	kW	hp	N/m
<b>B1 L1</b>	12	16	210	18	25	172
<b>B2 L2</b>	15	21	270	23	31	220
<b>B3 L3</b>	22	30	390	35	47	330
<b>B4 L4</b>	26	35	460	40	55	380
<b>B5 L5</b>	35	47	620	54	74	520
<b>B6 L6</b>	47	64	830	74	100	710
<b>B7</b>	55	75	970	87	118	830
<b>B8</b>	70	95	1240	110	150	1050
<b>B9</b>	88	120	1560	140	190	1340
<b>B10</b>	106	145	1890	170	230	1630
<b>L35</b>	39	53	690	61	83	580
<b>L36</b>	66	90	1167	102	139	974

Values related to continuous load, maximum 5 degree working angle



## USE AND SAFETY

### ENSURE THE FOLLOWING:

- Direction of PTO is correct
- PTO is secure at both ends
- Guard covers telescopic tubes after maximum extension
- Guard cover is secure at BOTH ends of PTO to tractor and implement
- Drive angles are the equal on both universals and working angle do NOT exceed 25°

Always wear correct safety equipment when handling the PTO. Carry the PTO horizontally so as to prevent halves sliding apart and causing damage.

## STORAGE

When the device is not in use, detach from equipment, store under cover in a dry place. Prior to re-use, ensure all components are functional and lubricated: replace any damaged parts before use

## LUBRICATION

Lubricate as per manufacturers instructions



### LUBRICATION PERIODS & POINTS

1	Guard Grease Nipples	<b>After every 8 working hours</b>
2	Cross journal	
3	Quick Release Pins	
4	Overrun & CVJ Clutches	
5	Steel Tubing	<b>After every 20 working hours</b>

### IZIKHATHI NEZINDAWO ZOKUGCOBA

1	Izivikeli Zezingono Zagrease	Ngemva kwamahora angu-8 okusebenza
2	Ijenali	Ngemva kwamahora angu-20 okusebenza
3	Izikhonkwane Zokukhipha Ngokushesha	
4	AmaClutch e-CVJ	
5	Amashubhu ensimbi	

## DANGER

ROTATING DRIVELINE CONTACT CAN CAUSE DEATH

### KEEP AWAY !

DO NOT OPERATE WITHOUT

- ALL DRIVELINE SHIELDS, TRACTOR AND EQUIPMENT SHEILDS IN PLACE
- DRIVELINES SECURITY ATTACHED AT BOTH ENDS
- DRIVELINES GUARDS THAT TURN FREELY ON DRIVELINE



## INGOZI

UKUTHINTA IDRIVELINE EJIKEZAYO KUNGABANGELA UKUFA

### QAPHELA !

UNGASEBENZI NGAPHANDLE

- KWAZO ZONKE IZIVIKELI ZE-DRIVELINE, EZAGANDAGANDA NEZOMSHINI ZISENDAWENI EFANELE
- KOKUVIKELEKA KWE-DRIVELINES KUNAMATHELE ZINDAWO ZOMBILI
- KWEZIVIKELI ZE DRIVELINE EZLIJKA NGOKUKHULULEKA KWI DRIVELINE





## GENERAL CHECKS

- Before installing the PTO, check that it has the suitable requisites with regards to power, length and any safety devices for the application.
- Ensure that the PTO has the prescribed protection and that it is correctly integrated by the tractor side and implement side protections.
- Ensure that when running, the PTO does not come in contact with parts of the tractor or implement. In particular, remove the tractor tow bar when not required. In case of towed machines or implements, ensure it does not come into contact with the PTO protection. Failing to adhere to this may cause damage to the tractor, machine or implement

## DANGERS

- Do not approach the PTO area whilst still in motion.
- Do not wear loose clothes that may get caught in the PTO – contact may cause very serious accidents and even death!
- Do not work with the PTO if its protection or parts thereof are missing. Any missing or damaged parts must be replaced immediately with original spare parts before using PTO.
- Ensure the tractor engine is switched off and key removed before any maintenance is done.
- Familiarise yourself with tractor, PTO and implement/machine operational instructions before operating and check if implement/machine needs a safety device, and if so, which type and ensure settings are correct.

## HOOK UP

- Ensure the tractor and implement / machine devices are well attached for hook up to the couplings
- Attach the anti-rotation chains to fixed points on the tractor and implement/machine, checking they do not obstruct articulation of the PTO or come into contact with any moving parts.
- Ensure that the tractor and implement / machine side protections are correctly installed and overlap those of the PTO
- Replace any missing or damaged parts immediately.
- NB - It is forbidden by law to use the PTO without its protection cover (guard) or without anti-rotation chains being properly connected to the PTO, tractor and implement/machine.

## LENGTHS

- Check that the maximum and minimum lengths are compatible with the required working lengths.
- NB: The PTO can only be extended 2/3 of its total length (end yoke to end yoke compressed), thus leaving a safe working 1/3 tubing overlap.

### Eg. PTO 1.2m in length

$$1200/3 = 400$$

$$400*2 = 800$$

$$800+1200 = 2000\text{mm}$$

Thus, PTO could be safely extended out to have a 2.0m working length.

## MAXIMUM WORKING ANGLES

1. Disengage drive whenever manoeuvres must be carried out that involves the angle of the joints to exceed 16° per side.

### MAXIMUM WORKING ANGLES FOR 80° HOMOKINETIC (CVJ) JOINTS - AFT6.CVJ

2. Operate this joint with a maximum angle of 50° for continuous working condition and 80° for brief periods only - eg. Steering.
3. Do not use the PTO as a support or running board - this could bend the tubing.
4. Do not use the anti-rotation chains to support or transport the PTO when detached from the tractor.



PART NO. AFT6.CVJ

CVJ - WIDE ANGLE

## CARDAN TRANSMISSION

Cardan transmission is usually used where power transmission is required between two non-aligned shafts. It can be realized by means of a single joint, two joints and up to three joints in more particular circumstances.

The single cardan joint is used in transmissions between two coplanar shafts, axes that form a certain angle and are at a fixed approach distance.

The double cardan joint is usually used when the axes are not opposing but oblique or at a reciprocal distance such as to make it impossible to use a single joint. In cases where the shafts are at a variable distance, we use double cardan joint transmissions, in which the two joints are connected by telescopic tubing. This is the most versatile and most common type of configuration used in power transmission between tractors and agricultural machinery.

Three joint transmission is used for even greater distances between shafts and in order to reduce transmission irregularity. The transmission requires a further central support for the intermediary joint.

$\alpha_1=18^\circ, \alpha_2=15^\circ$   
 $\Delta i=3.1\%$

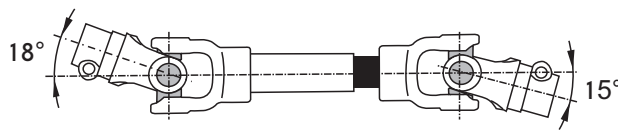

$\alpha_1=20^\circ, \alpha_3=10^\circ, \alpha_2=21^\circ$   
 $\Delta i=4.4\%$

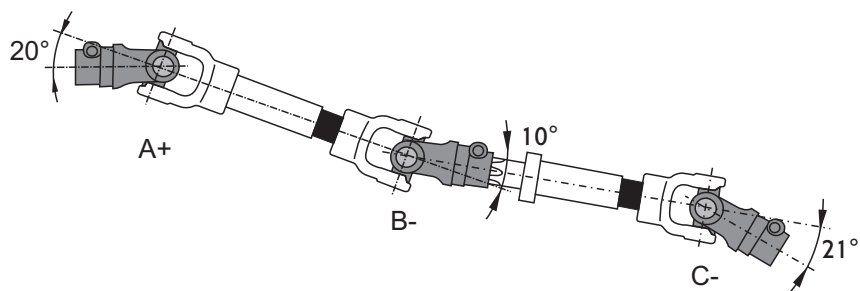

$\alpha_1=20^\circ, \alpha_3=10^\circ, \alpha_2=11^\circ$   
 $\Delta i=13.1\%$

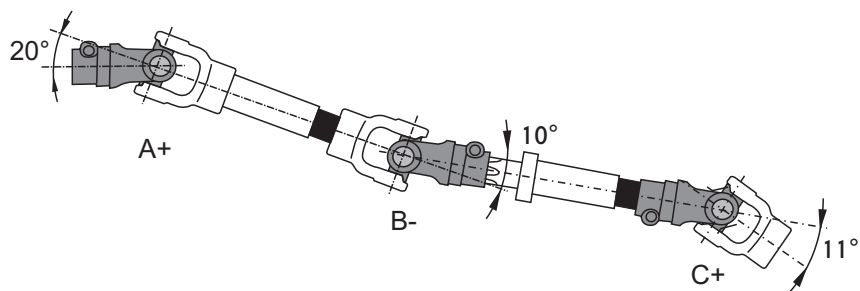

## OPERATING MACHINES WITH 3 POINT ATTACHMENTS

In case of machines connected by means of a three-point attachment, under working conditions the situation appears as shown in fig. 1.1. In such a condition it is best to have the two attachment shafts of the tractor and operating machine as parallel and aligned as possible in order to favour homokineticism or at least to limit the transmission irregularly. In this position the cardan transmission is in a condition of minimum length as the joint angles are also minimal.

If the machine is raised, the situation is as shown in fig. 1.2. In this condition as the result of the kinematics of the attached device, the transmission is extended to the maximum. The joint angles also increase, therefore it is necessary to stop the transmission.

## TOWED OPERATING MACHINES

With towed operating machines, usually when the transmission is straight it is also at its maximum length, while when steering the length is reduced as the steering angle is increased.

When steering, the two joints of the transmission assume an angle in relation to the attachment point of the machine on the tractor.

In case this point has the equal distance between the two PTO's of the tractor and the operating machine, the two  $\alpha_1$  and  $\alpha_2$  angles are equal and therefore the transmission is homokinematic.

In case the connection point is near the tractor, or less commonly, near the operating machine, the two angles  $\alpha_1$  and  $\alpha_2$  are equal and the joint nearest to the attachment point is subject to a greater angle than the other. For example in fig. 1.1 the attachment point is nearer to the tractor and therefore  $\alpha_1 > \alpha_2$ . Note that if the attachment point comes coincided with the axis of one of the two joints, the angularity of the other would be reduced until it is cancelled.

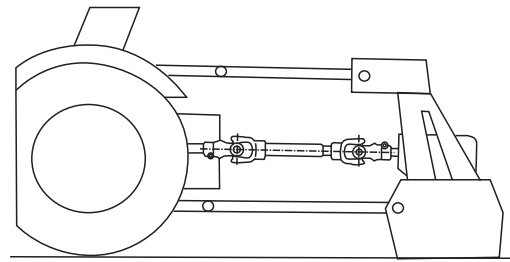

fig. 1.1

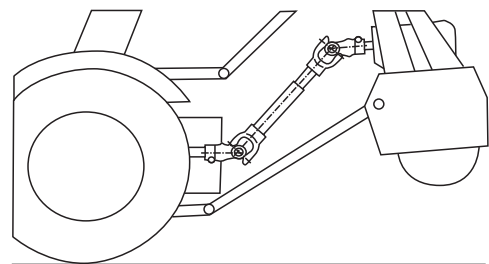

fig. 1.2

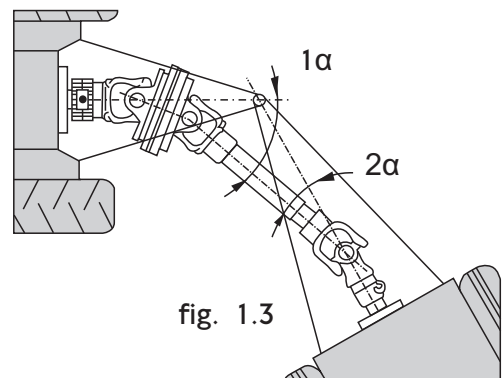

fig. 1.3

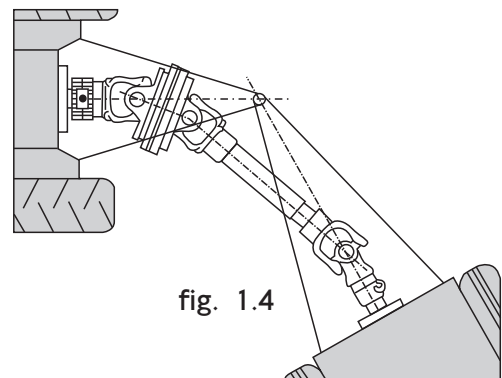

fig. 1.4

## POPULAR SIZES







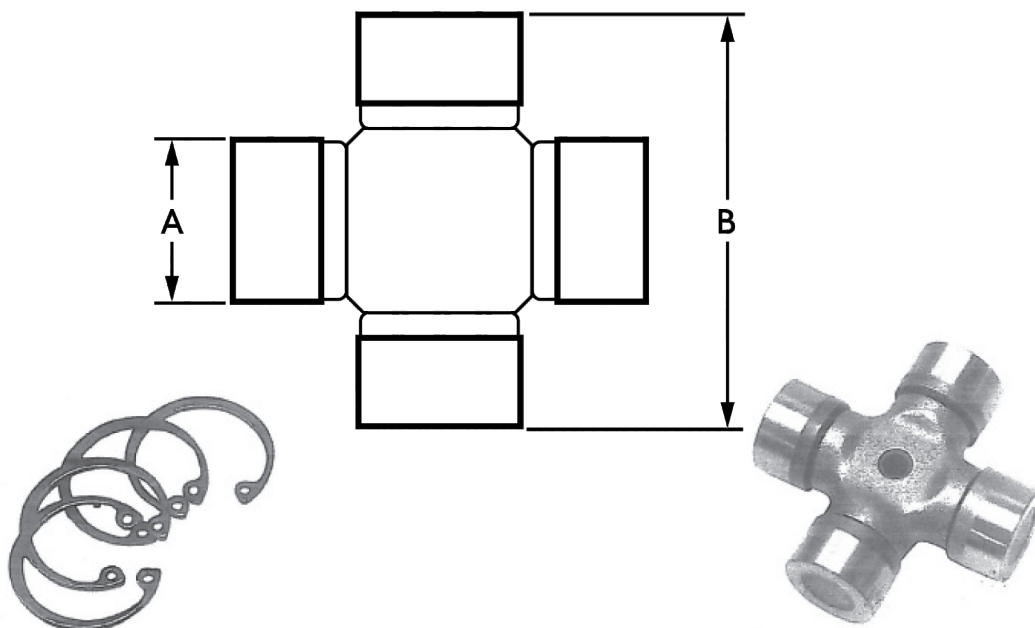



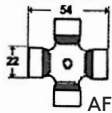
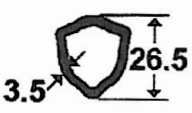

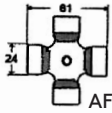

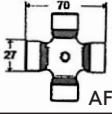
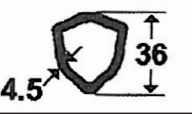

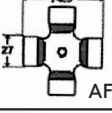
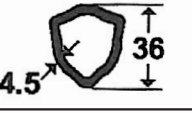

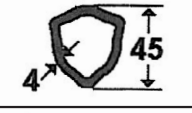
SHAFT SIZE	REFERENCE NUMBER	A mm	B mm
<b>B1 L1</b>	AFT1.41A	22	54
<b>B2 L2</b>	AFT2.41A	24	61
<b>B3 L3</b>	AFT3.41A	27	70
<b>B4 L4</b>	AFT4.41A	27	74.5
<b>B7</b>	AFT7.41A	30	106.5
<b>B5 L5</b>	AFT5.41A	30.2	80
<b>B6 L6</b>	AFT6.41A	30.2	92
<b>L35</b>	AFT35.41	32	76
<b>L12</b>	AFT12.41	34	90
<b>B7 N</b>	AFT7.81A	35	94
<b>B8</b>	AFT8.41A	35	106.5

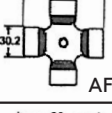
## UNPOPULAR SIZES

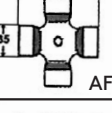
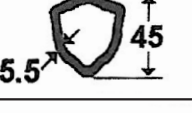
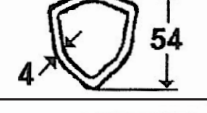
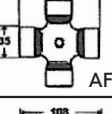
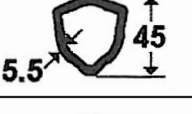
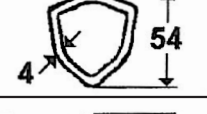
REFERENCE NUMBER	A mm	B mm
AFT1.41L	22	55
AFT30.41A	29	80
AFT6.41C	30.2	100
AFT60.41A	34	106.5
AFT36.41	36	89
AFT25.41	39.6	116
AFT9.81A	41	108
AFT10.41A	41	118
AFT26.41	42	104

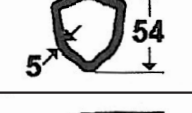

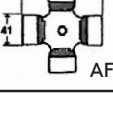
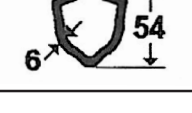
# STEEL TUBING : TRIANGULAR







SHAFT SIZE	REFERENCE		U. JOINT	TUBE	
				INNER A	OUTER B
B1	A	AFT1.04			
	B	AFT1.03		AFT1.41A	
B2	A	AFT2.04			
	B	AFT2.03		AFT2.41A	
B3	A	AFT4.04			
	B	AFT3.03		AFT3.41A	
B4	A	AFT4.04			
	B	AFT3.03		AFT4.41A	
B5	A	AFT5.04			
	B	AFT5.03		AFT5.41A	
B6	A	AFT5.04			
	B	AFT6.03		AFT6.41A	
B7	A	AFT7.04			
	B	AFT6.03		AFT7.41A	
B8	A	AFT7.04			
	B	AFT6.03		AFT8.41A	
B8OT	A	AFT8.04			
	B	AFT8.03		AFT9.41A	
B10	A				
	B			AFT10.41A	

Non standard lengths available. Contact BMG with your special requirements.

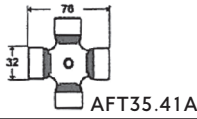
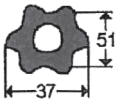
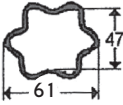
SHAFT SIZE	REFERENCE		U. JOINT	TUBE	
				INNER A	OUTER B
L1	A	AFT104LP			
	B	AFT103LP			
L2	A	AFT404LP			
	B	AFT303LP			
L3	A	AFT404LP			
	B	AFT303LP			
L4	A	AFT404LP			
	B	AFT303LP			
L35	A	AFT504LP			
	B	AFT603LP			
L6	A	AFT504LP			
	B	AFT603LP			
L36	A	AFT504LP			
	B	AFT603LP			

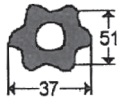
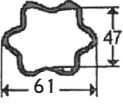
Non standard lengths available. Contact BMG with your special requirements.

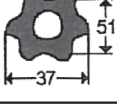
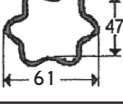
# STEEL : TUBING STAR

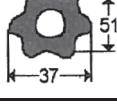
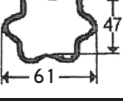
SHAFT SIZE	REFERENCE	U. JOINT	TUBE	
			INNER A	OUTER B
S35	A AFTS4	 AFT35.41A	 37 51	 47 61
	B AFTS5			
S36	A AFTS4	 AFT36.41A	 37 51	 47 61
	B AFTS5			
S6	A AFTS4	 AFT6.41A	 37 51	 47 61
	B AFTS5			
S8	A AFTS4	 AFT8.41A	 37 51	 47 61
	B AFTS5			

## SPLINE SHAFTING

**PART NO: AFTAD6.SB (1 $\frac{3}{8}$  6 SPLINE BAR)**

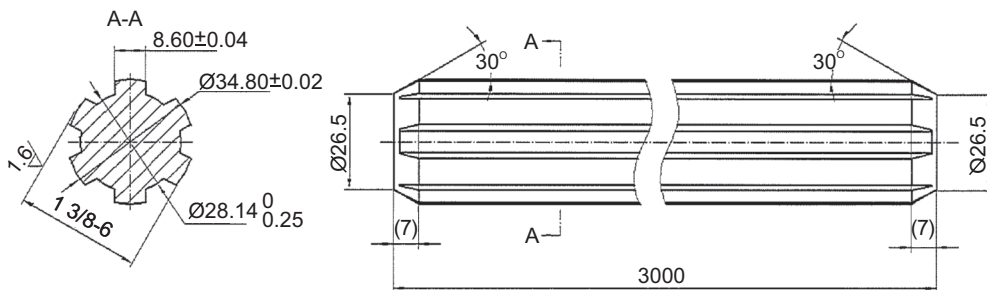

**PART NO: AFTAD20SB (20 SPLINE BAR)**

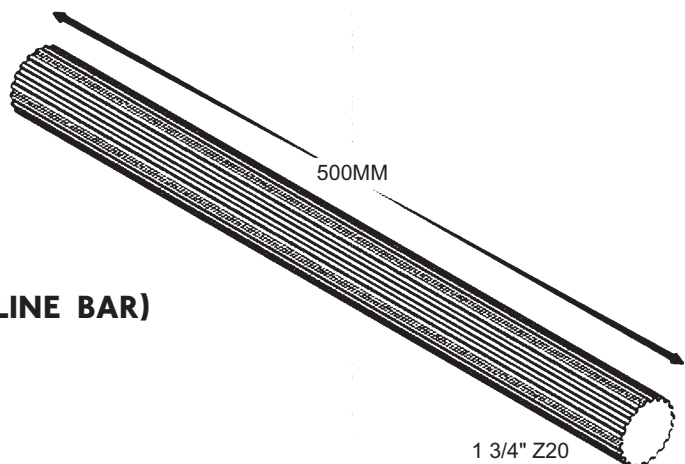



# TUBE YOKES : TRIANGULAR

SHAFT SIZE	REFERENCE NUMBER	A mm	B mm	C mm	INNER/ OUTER
<b>B1</b>	AFT1.07	22	54	26.5	INNER
	AFT1.06	22	54	32.5	OUTER
<b>B2</b>	AFT2.07	23.8	61	29	INNER
	AFT2.06	23.8	61	36	OUTER
<b>B3</b>	AFT3.07	27	70	36	INNER
	AFT3.06	27	70	43.5	OUTER
<b>B4</b>	AFT4.07	27	74.5	36	INNER
	AFT4.06	27	74.5	43.5	OUTER
<b>B7</b>	AFT7.07	30	106.5	45	INNER
	AFT7.06	30	106.5	54	OUTER
<b>B5</b>	AFT5.07	30.2	80	45	INNER
	AFT5.06	30.2	80	51.6	OUTER
<b>B6</b>	AFT6.07	30.2	92	45	INNER
	AFT6.06	30.2	92	54	OUTER
<b>B7 N</b>	AFT7N.07	35	94	45	INNER
	AFT7N.06	35	94	54	OUTER
<b>B8</b>	AFT8.07	35	106.5	45	INNER
	AFT8.06	35	106.5	54	OUTER
	AFT8.07 O/T	35	106.5	53	INNER
	AFT8.06 O/T	35	106.5	63	OUTER
<b>B10</b>	AFT10.07	41	118	54	INNER
	AFT10.06	41	118	66	OUTER

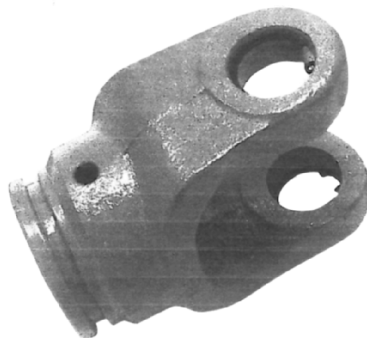
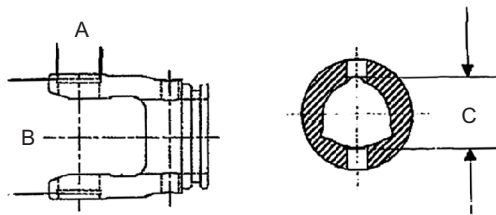

**BOER**  
SLIM

# TUBE YOKES : LEMON

SHAFT SIZE	REFERENCE NUMBER	A mm	B mm	C mm	INNER/ OUTER
L1	AFT1.07LP	22	55	31	INNER
	AFT1.06LP	22	55	39	OUTER
L2	AFT2.07LP	24	61	40	INNER
	AFT2.06LP	24	61	48	OUTER
L3	AFT3.07LP	27	70	40	INNER
	AFT3.06LP	27	70	48	OUTER
L4	AFT4.07LP	27	74.5	40	INNER
	AFT4.06LP	27	74.5	48	OUTER
L6	AFT6.07LP	30.2	92	49	INNER
	AFT6.06LP	30.2	92	57.5	OUTER
L35	AFT35.07LP	32	76	49	INNER
	AFT35.06LP	32	76	57.5	OUTER

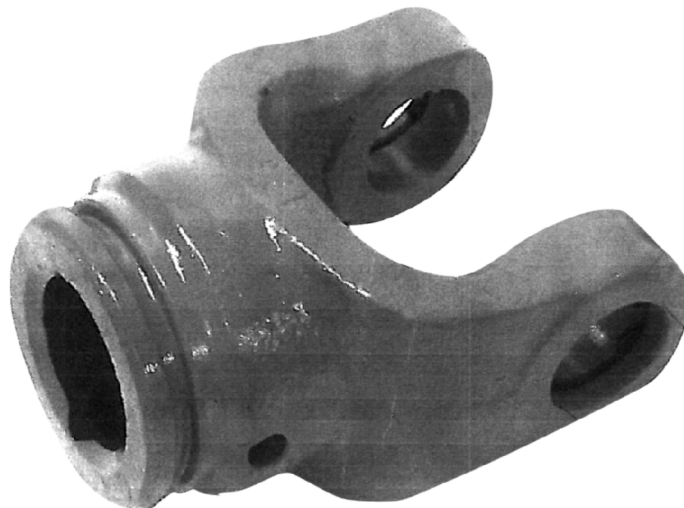
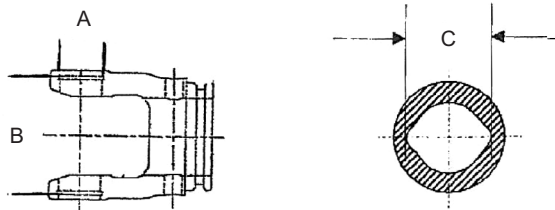

REFERENCE NUMBER	A mm	B mm	C mm
AFT35.07S	76	32	51
AFT35.06S	76	32	61
AFT36.07S	89	36	51
AFT36.06S	89	36	61
AFT6.07S	92	30	51
AFT6.06S	92	30	61
AFT24.07S	106.5	35	51
AFT24.06S	106.5	35	61

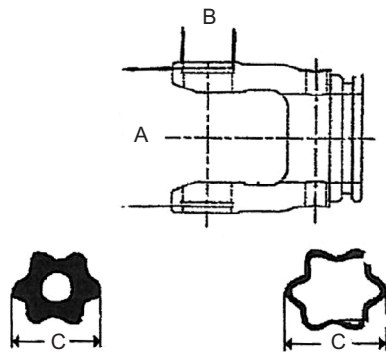

# QUICK RELEASE YOKES

SHAFT SIZE	1.1/8 6 SPLINE	1.3/8 6 SPLINE	1.3/8 21 SPLINE	1.3/4 6 SPLINE	1.3/4 20 SPLINE		
B1 L1	AFT1.05.03	AFT1.05.07	AFT1.05.08	----	----	22	54
B2 L2	AFT2.05.03	AFT2.05.07	AFT2.05.08	----	----	24	61
B3 L3	----	AFT3.05.07	----	----	----	27	70
B4 L4	----	AFT4.05.07	AFT4.05.08	----	----	27	74.5
B7	----	AFT7.05.07	----	----	----	30	106.5
B5 L5	----	AFT5.05.07	----	----	----	30.2	80
B6 L6	----	AFT6.05.07	AFT6.05.08	AFT6.05.09	AFT6.05.10	30.2	92
L35	----	AFT35.05.07	AFT35.05.08	----	----	32	76
B7 N	----	AFT7N.05.07	----	----	----	35	94
B8	----	AFT8.05.07	AFT8.05.08	AFT8.05.09	AFT8.05.10	35	106.4
L36	----	AFT36.05.07	AFT36.05.08	AFT36.05.09	AFT36.05.10	36	89
B10	----	AFT10.05.07	----	----	----	41	
	----	AFT26.05.07	----	----	----	42	104

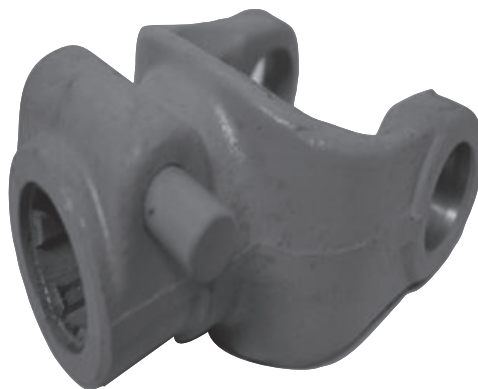
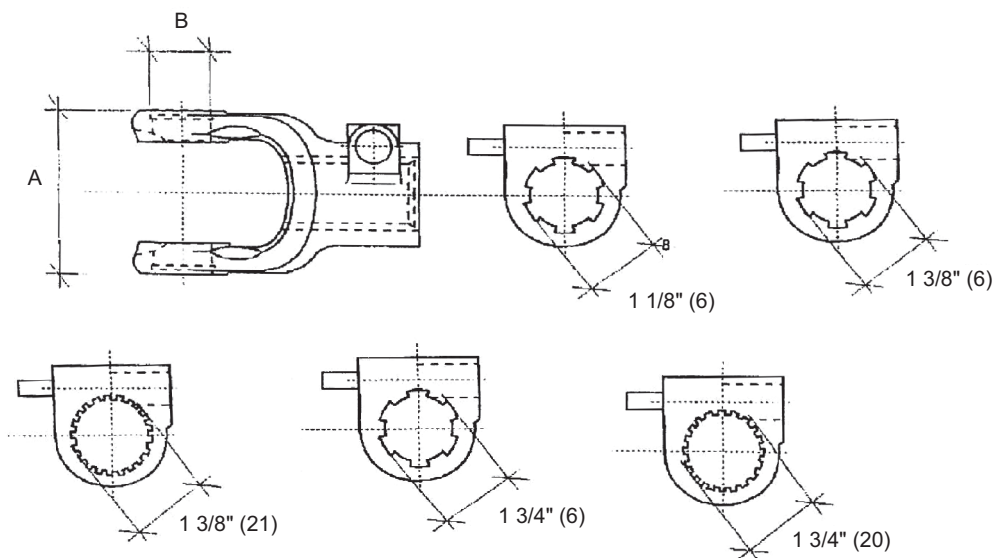

**BOER**  
SLIM

# INTERFERING BOLT YOKES 6 SPLINE

SHAFT SIZE	REFERENCE NUMBER	A mm	B mm
<b>B2 L2</b>	AFT2.05.17	24	61
<b>B4 L4</b>	AFT4.05.17	27	74.5
<b>B6 L6</b>	AFT6.05.17	30.2	92

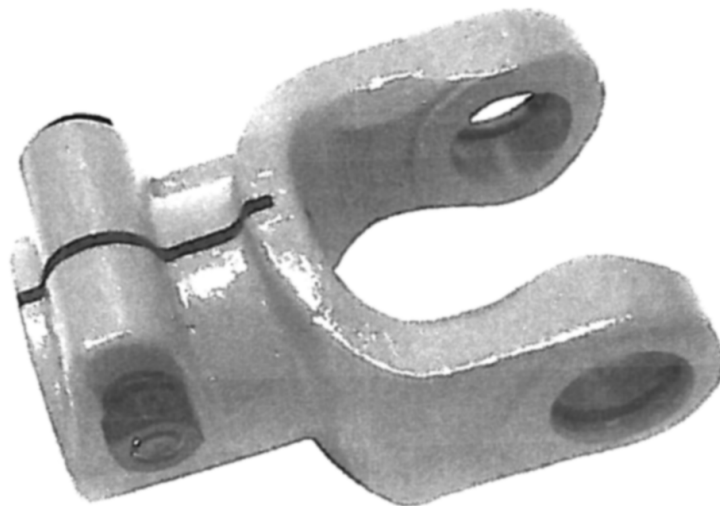
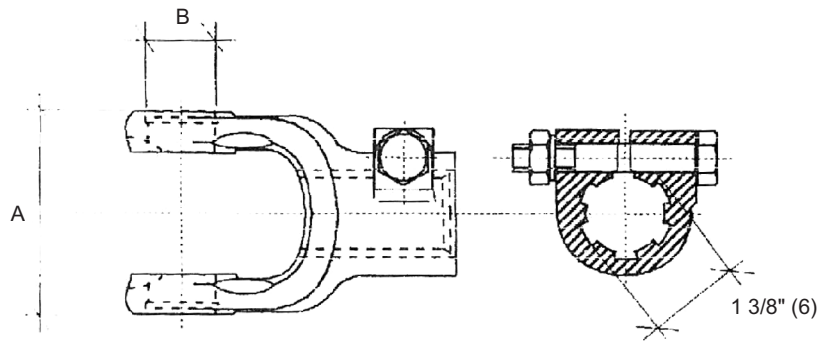

# NON-INTERFERING BOLT YOKES

SHAFT SIZE	REFERENCE NUMBER	A mm	B mm	C mm
<b>B1 L1</b>	AFT1.05.20	22	54	20
	AFT1.05.25	22	54	25
	AFT1.05.30	22	54	30
	AFT1.05.32	22	54	32
<b>B2 L2</b>	AFT2.05.25	24	61	25
	AFT2.05.30	24	61	30
	AFT2.05.32	24	61	32
	AFT2.05.35	24	61	35
<b>B3 L3</b>	AFT3.05.25	27	70	25
	AFT3.05.30	27	70	30
<b>B4 L4</b>	AFT4.05.25	27	74.5	25
	AFT4.05.30	27	74.5	30
	AFT4.05.32	27	74.5	32
	AFT4.05.35	27	74.5	35
	AFT4.05.38	27	74.5	38
<b>B6 L6</b>	AFT6.05.25	30.2	92	25
	AFT6.05.30	30.2	92	30
	AFT6.05.32	30.2	92	32
	AFT6.05.35	30.2	92	35
	AFT6.05.38	30.2	92	38
	AFT6.05.40	30.2	92	40
	AFT6.05.45	30.2	92	45
	AFT6.05.50	30.2	92	50
<b>B8</b>	AFT8.05.45	35	106.5	45

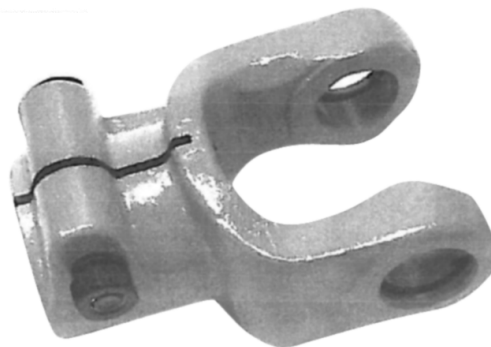
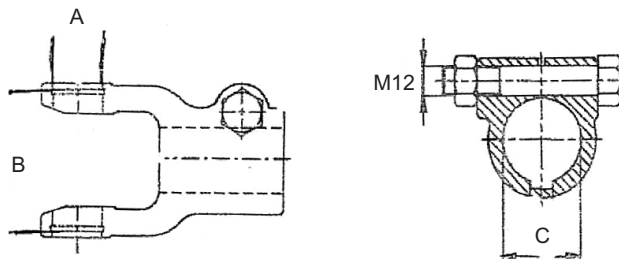

# PLAIN METRIC BORE YOKES

SHAFT SIZE	REFERENCE METRIC	A mm	B mm	C mm
<b>B1 L1</b>	AFT1.02.20	22	54	20
	AFT1.02.25	22	54	25
	AFT1.02.30	22	54	30
	AFT1.02.32	22	54	32
<b>B2 L2</b>	AFT2.02.25	24	61	25
	AFT2.02.30	24	61	30
	AFT2.02.32	24	61	32
<b>B4 L4</b>	AFT4.02.25	27	74.5	25
	AFT4.02.30	27	74.5	30
	AFT4.02.32	27	74.5	32
	AFT4.02.35	27	74.5	35
<b>B6 L6</b>	AFT6.02.35	30.2	92	35
	AFT6.02.40	30.2	92	40

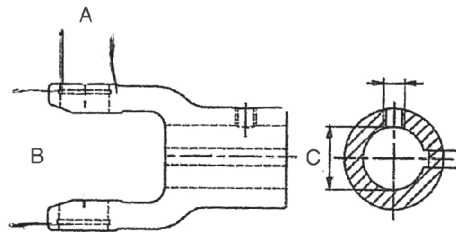

# HEX CLAMP BOLT YOKES

SHAFT SIZE	REFERENCE	A mm	B mm	C mm
B2 L2	AFT2.05.HEX	22	61	28.5
B4 L4	AFT4.05.HEX 25	27	74.5	25
B4 L4	AFT4.05 HEX	27	74.5	28.5
B4 L4	AFT4.05 HEX 32	27	74.5	32
B6 L6	AFT6.05 HEX	30.2	92	28.5
B6 L6	AFT6.05 HEX 32	30.2	92	32
B6 L6	AFT6.05 HEX 28.7	30.2	94.5	28.7

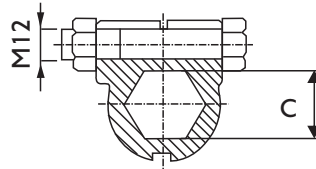
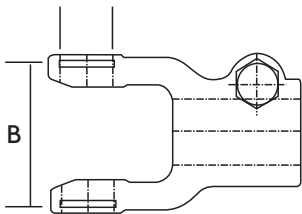

# SOLID BORE YOKES

SHAFT SIZE	REFERENCE	A mm	B mm
B1 L1	AFT1.01.SB	22	54
B2 L2	AFT2.01.SB	24	61

SHAFT SIZE	KEYWAY
20	6mm
25	8mm
30	8mm
32	10mm
35	10mm
38	12mm
40	12mm
45	12mm
50	12mm

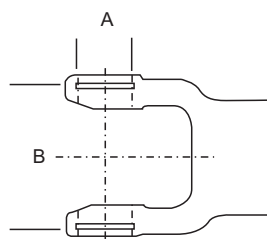



# PLASTIC GUARD COMPONENTS

SERIES	1 INNER BEARING	2 + 3 INNER CONE	4 GREASE NIPPLE	5 INNER TUBE	6 OUTER TUBE	7 + 2 OUTER CONE	8 OUTER BEARING	9 CHAIN
1	AFT101B	AFT402C	AFT200	AFT402T	AFT401T	AFT401C	AFT101B	AFT100
2	AFT201B	AFT402C	AFT200	AFT402T	AFT401T	AFT401C	AFT201B	AFT100
4	AFT401B	AFT402C	AFT200	AFT402T	AFT401T	AFT401C	AFT401B	AFT100
6	AFT601B	AFT602C	AFT200	AFT602T	AFT601T	AFT601C	AFT601B	AFT100
8	AFT801B	AFT802C	AFT200	AFT802T	AFT801T	AFT801C	AFT801B	AFT100
35	AFT602B	AFT602C	AFT200	AFT602T	AFT601T	AFT601C	AFT602B	AFT100
36	AFT601B	AFT601C	AFT200	AFT602T	AFT602T	AFT601C	AFT601B	AFT100

Care must be taken on the 8 series guards, they can take the 802b, yoke bearing groove diameter must be measured if not sure.

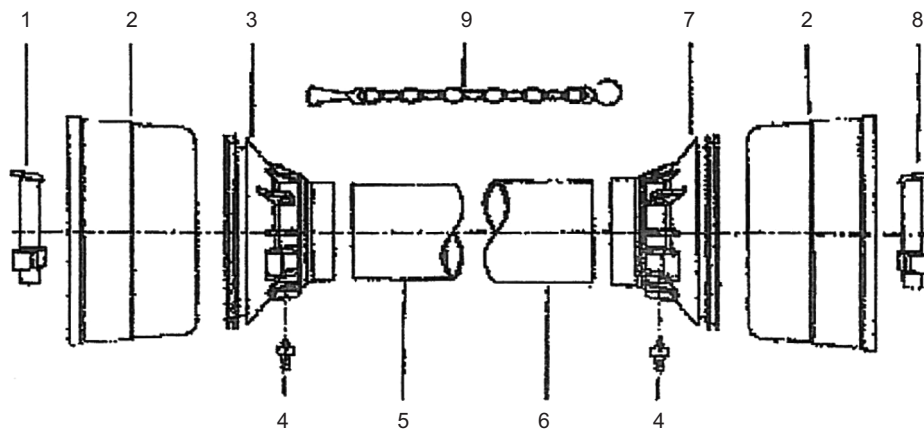

## Guard Bearing Sizes

REFERENCE	A mm	B mm
AFT101B	42	70
AFT201B	48	70
AFT401B	54	70
AFT601B	69	85
AFT602B	62	85
AFT603B	52	85
AFT802B	67	96
AFT801B	78	96

## Guard Tubing

REFERENCE	ID	OD	INNER/ OUTER
AFT401T	62	67	Outer
AFT402T	56	61.5	Inner
AFT601T	77	82	Outer
AFT602T	72	76.5	Inner
AFT801T	90	94	Outer
AFT802T	85	89.5	Inner

## QUICK RELEASE YOKE PINS

REFERENCE	A mm	B mm	C mm
AFT1082501	14	47	27
AFT10825SS	14	70.7	30
AFT10825	14	80	30
AFT10825HS	14	84	30
AFTQR.RM.BB	16	89	65

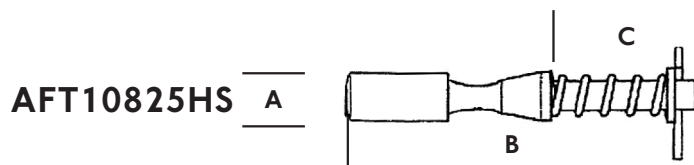
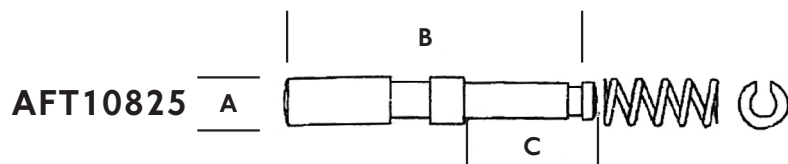

SHAFT SIZE	TYPE 1 CLUTCH TYPE (YOKE FLANGE)	SPLINES	QTY OF PLATES	A mm	B mm	C mm	TYPE 2 MALE FLANGE
<b>B4 L4</b>	AFT4.FF1	1.3/8 6 SPLINE	2	27	74.5	140	----
<b>B6 L6</b>	AFT6.FF2	1.3/8 6 SPLINE	2	30.2	92	160	----
	AFT6.FF2.05.10	1.3/4 20 SPLINE	2	30.2	92	160	----
	AFT6.FF4	1.3/8 6 SPLINE	4	30.2	92	160	----
	AFT6.FF4.05.09	1.3/4 6 SPLINE	4	30.2	92	160	----
	AFT6.FF4.05.10	1.3/4 20 SPLINE	4	30.2	92	160	----
<b>B8</b>	AFT8.FF4	1.3/8 6SPLINE	4	35	106.5	160	----
	AFT8.FF4.05.09	1.3/4 6 SPLINE	4	35	106.5	160	----
	AFT8.FF4.05.10	1.3/4 20 SPLINE	4	35	106.5	160	----
<b>B4 L4</b>		1.3/8 6 SPLINE	2			140	AFT4.FFDM1
<b>B6 L6</b>		1.3/8 6 SPLINE	2			160	AFT6.FFDM2

Purpose of this clutch is to start spinning once torque exceeds set limit, to prevent damage to implement.

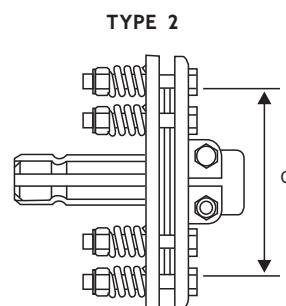
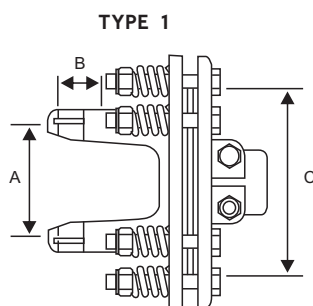

**Torque Rating: @ 540 RPM**

**AFT4.FF1 = 800Nm**

**AFT6.FF2 = 1800Nm**

**AFT8.FF4 = 2300Nm**

# OVERRUN AND SHEAR BOLT CLUTCHES

## OVERRUN CLUTCHES

SHAFT SIZE	TYPE 1 REFERENCE	A mm	B mm	SPLINES	TYPE 2
B4 L4	AFT4.OR.S	27	74.5	1.3/8 6 SPLINE	
B6 L6	AFT6.OR.S 21SPLINE	30.2	92	1.3/8 21 SPLINE	
B6 L6	AFT6.OR.S	30.2	92	1.3/8 6 SPLINE	AFTM.OR.S

Purpose of this clutch is to allow the implement to run down (speed) slowly while tractor stops (this is when implement needs more time to slow down to a stop than the tractor)

TYPE 1



TYPE 2

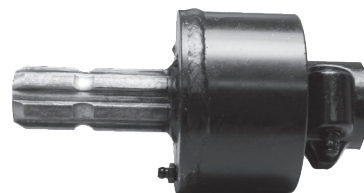

## SHEAR BOLT CLUTCH

SHAFT SIZE	REFERENCE	SPLINE	A mm	B mm	BOLT SIZE
B2 L2	AFT2.SB	1.3/8 6 SPLINE	24	61	6 x 50 HTB
B4 L4	AFT4.SB	1.3/8 6 SPLINE	27	74.5	8 x 50 HTB
B6 L6	AFT6.SB	1.3/8 6 SPLINE	30.2	92	8 x 65 HTB
B8	AFT8.SB	1.3/8 6 SPLINE	35	106.5	10 x 70 HTB

Purpose of this clutch is to shear the bolt off when torque is too high, to prevent damage to PTO or implement.

**NB! ONLY USE HT BOLTS.**

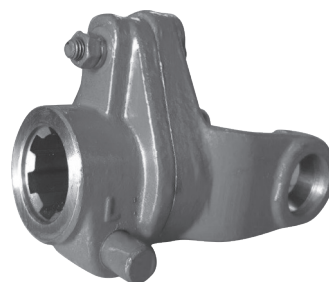
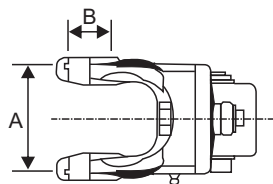

# FRICION CLUTCH REPLACEMENTS PARTS (OLD TYPE)

ART	REFERENCE	DESCRIPTION	CROSS JOURNAL		NO 5 mm	REQ QTY	SPLINES	SIZE
			A mm	B mm				
1	—	HT Bolt	—	—	—	8	—	M10 x 90HT
1	—	HT Bolt	—	—	—	8	—	M10 x 100HT
2	AFTFF1.2	Back Plate	—	—	140	1	—	—
2	AFTFF2.2	Back Plate	—	—	160	1	—	—
3	AFTFF1.3	Clutch Plate	—	—	—	2	—	85 x 140 x 3
3	AFTFF2.3	Clutch Plate	—	—	—	2/4	—	97.5 x 160 x 3
4	—	HT Bolt	—	—	—	2	—	M12 x 80HT
5	AFTFF1.5	Centre Hub	—	—	140	1	1.3/8 6 Spline	----
5	AFTFF2.5 AFTFF2.5 NEW	Centre Hub	—	—	160 140	1	1.3/8 6 Spline	----
5	AFTFF4.5	Centre Hub	—	—	160	1	1.3/8 6 Spline	----
5	AFTFF2.5.10	Centre Hub	—	—	160	1	1.3/4 20 Spline	----
5	AFTFF4.5.10	Centre Hub	—	—	160	1	1.3/4 20 Spline	----
5	AFTFF2.05.21	Centre Hub	—	—	160	1	1.3/8 21 Spline	----
5	AFTFF4.5.09	Centre Hub	—	—	160	1	1.3/4 6 Spline	----
6	AFTFF2.6	Friction Ring	—	—	—	1	----	—
7	AFTFF2.7	Friction Plate	—	—	—	1	----	----
8	AFTFF2.8	Friction Plate	—	—	—	1	----	----
9	AFT4.FF1.9	Flange Yoke	27	74.5	140	1	----	----
9	AFT6.FF2.9	Flange Yoke	30.2	92	160	1	----	----
9	AFT8.FF2.9	Flange Yoke	35	106.5	160	1	----	----
10	AFTFF2.11	Spring	—	—	—	8	----	6.4 x 38

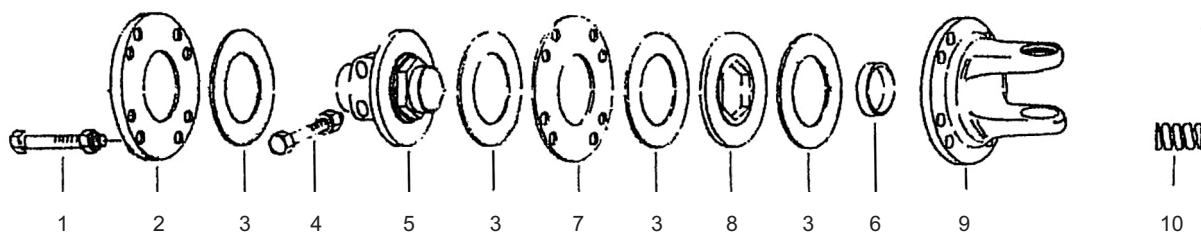

### Clutch torque settings mm/Nm

mm	Nm
27	9.5
26	10
25	10.5

## STANDARD COMPONENT FOR 1 METRE SZ PTO'S (2 TRACTOR YOKES)

SERIES	INNER TUBE	OUTER TUBE	TUBE LENGTH	INNER TUBE YOKE	OUTER TUBE YOKE	CROSS JOURNAL	END YOKES	GUARD
<b>B1</b>	AFT1.04	AFT1.03	0.7	AFT1.07	AFT1.06	AFT1.41A	AFT1.05.07	AFT101.10
<b>B2</b>	AFT2.04	AFT2.03	0.6	AFT2.07	AFT2.06	AFT2.41A	AFT2.05.07	AFT201.10
<b>B4</b>	AFT4.04	AFT3.03	0.6	AFT4.07	AFT4.06	AFT4.41A	AFT4.05.07	AFT401.10
<b>B6</b>	AFT5.04	AFT6.03	0.6	AFT6.07	AFT6.06	AFT6.41A	AFT6.05.07	AFT601.10
<b>B8</b>	AFT7.04	AFT6.03	0.6	AFT8.07	AFT8.06	AFT8.41A	AFT8.05.07	AFT601.10
<b>L1</b>	AFT104LP	AFT103LP	0.7	AFT1.07LP	AFT1.06LP	AFT1.41A	AFT1.05.07	AFT101.10
<b>L2</b>	AFT404LP	AFT303LP	0.6	AFT2.07LP	AFT2.06LP	AFT2.41A	AFT2.05.07	AFT201.10
<b>L4</b>	AFT404LP	AFT303LP	0.6	AFT4.07LP	AFT4.06LP	AFT4.41A	AFT4.05.07	AFT401.10
<b>L6</b>	AFT504LP	AFT603LP	0.6	AFT6.07LP	AFT6.06LP	AFT6.41A	AFT6.05.07	AFT601.10

### QUICK RELEASE PINS (QRP)

AFT1.05.07	AFT10825SS
AFT2.05.07	AFT10825SS
AFT3.05.07	AFT10825SS
AFT4.05.07	AFT10825SS
AFT5.05.07	AFT10825HS
AFT6.05.07	AFT10825
AFT35.05.07	AFT10825HS
AFT7.05.07	AFTQR.RM.BB
AFT7N.05.07	AFT10825HS
AFT8.05.07	AFTQR.RM.BB

### TENSION PINS

B/L1	8 X 50	AFT1.13
B/L2	8 X 55	AFT2.13
B/L4	8 X 65	AFT4.13
B/L6	10 X 80	AFT6.13
B8	10 X 80	AFT6.13

All new QR yokes use one pin namely: AFT1082501

## TUBE AND GUARD CUT LENGTHS

PTO	STEEL TUBING (mm)	GUARD TUBE (mm)
B/L46	300	230
B/L17	400	330
B/L28	400	330
B/L110	700	630
B/L112	900	830
B/L210	600	540
B/L212	800	730
B/L410	600	540
B/L412	800	730
B/L610	600	540
B/L612	800	730
B/L615	1100	1030
B/L618	1400	1330
B/L620	1600	1530
B/L625	2100	2030

When ordering replacement steel tubing, 400mm must be deducted from total PTO length to get correct tubing length. This however, is not applicable to the 1 Series where 300mm must be deducted.

## STANDARD GUARD CUT LENGTHS

PTO SERIES	REFERENCE TO FIT PTO
B/L110	AFT101.10
B/L112	AFT101.12
B/L210	AFT201.10
B/L212	AFT201.12
B/L410	AFT401.10
B/L412	AFT401.12
B/L610	AFT601.10
B/L612	AFT601.12
B/L810	AFT801.10
B/L812	AFT801.12

When ordering Guard covers, it must be remembered that the total PTO length (compressed, end yoke to end yoke) must be given, if cover size is not known.

SHAFT	KEYWAY
20	6mm
25	8mm
30	8mm
32	10mm
35	10mm
38	12mm
40	12mm
45	12mm
50	12mm



## YOKE ARM WEAR

### Cause:

- Excessive working angles on swivels

### Remedial Action:

- Reduce swivel working angle
- Disengage the drive for angles which are wider than prescribed

## DEFORMATION OF YOKE ARMS

### Cause:

- Excessive torque peaks

### Remedial Action:

- Avoid brusque engagements of the drive with transmission under load
- Avoid excessive overloads during operation
- Avoid brusque drive interruptions with high inertia machines
- Check function of safety device eg. clutch, shear bolt

## EXCESSIVE WEAR OF CROSS JOURNAL PINS

### Causes:

- Excessive working power
- Insufficient lubrication

### Remedial Action:

- Avoid exceeding the power and speed prescribed
- Lubricate the cross and all other points every 20 working hours

## CROSS JOURNAL BREAKAGE

### Cause:

- Excessive torque peaks
- Excessive working angles on swivels
- Excessive vibration on PTO

### Remedial Action:

- Avoid brusque engagement of the drive with the PTO under load
- Avoid excessive overloads during operation
- Disengage the drive for angles that are wider than prescribed
- Check and replace any damaged parts on the PTO that may cause vibration
- Avoid brusque drive interruptions with high inertia machines
- Ensure safety devices are working correctly and set correctly



## UNDOING OF TELESCOPIC TUBES

### Cause:

- Tubes undoing when in use

### Remedial Action:

- Check if PTO length is suitable for the application
- Ensure sufficient overlap of tubes is present – if in the maximum PTO lengthening condition

NB: Lengthening of tubes MUST NOT exceed 2/3 of the total PTO length

## WEAR OF TELESCOPIC TUBES

### Cause:

- Insufficient lubrication
- Insufficient overlap
- Excessive torque on PTO
- Excessive vibration on PTO

### Remedial Action:

- Lubricate tubes and ALL points of the shaft (recommended every 20 working hours)
- Ensure correct shaft length is used for application
- Ensure sufficient overlap of tubes is present – if in the maximum PTO lengthening condition
- Check for excessive vibration of PTO
- Ensure torque load of PTO is within specifications for application
- Avoid brusque drive interruptions with high inertia machines

## DEFORMATION OF TUBES

### Cause:

- Excessive torque peaks

### Remedial Action:

- Ensure PTO dimensions are adequate for load to be transmitted
- Avoid brusque engagements of the drive with PTO under load
- Avoid excessive overloads during operations
- Avoid brusque drive interruptions with high inertia machines
- Check functioning of safety devices
- Check that PTO is not coming into contact with tractor or implement while functioning or in a manoeuvre

- In PTO's with wide angle joints, check that during manoeuvres, the join is not forced beyond the prescribed angle
- Ensure area of operation is free of obstacles that could cause high torque peaks

## **BINDING OF TELESCOPIC TUBES**

### **Cause:**

- Insufficient lubrication
- Tubes distorted (see deformation of tube)
- Excessive rust

### **Remedial Action:**

- Lubricate tubes as per manufacturer's instructions
- Remove rust and lubricate

## **EARLY WEAR OF BEARING COLLARS**

### **Cause:**

- Insufficient lubrication

### **Remedial Action:**

- Lubricate as per manufacturer's instructions (recommended every 20 working hours)

## **BLOCKING OR MALFUNCTION OF SAFETY DEVICES**

### **Cause:**

- Long period of non-use in damp surroundings
- Excessive or over tightening of tension springs

### **Remedial Action:**

- Dismantle safety device, clean internal parts, replace if need be, lubricate and reassemble
- For long periods of non-use – store device under cover in a dry place
- Avoid over tightening of springs – this can cause malfunction of safety device (recommended tightening = 25 – 27mm spring length)



# BRINGING THE WORLD'S BEST BRANDS TO YOU

In the bid to procure cutting-edge components at competitive prices, BMG is able to capitalise on long-standing relationships with leading manufacturers dedicated to excellence in design and production.

Products are imported from around the globe and brought to BMG's strategically located distribution facilities and regional service centres via the main distribution hub in Johannesburg - BMG World. A world-class facility boasting 308 000m<sup>3</sup> of fully stocked warehouse space, an accredited training facility and unlimited engineering capabilities.

## Our Extensive Coverage Throughout Africa

**88**  
BRANCHES

Products and services are distributed via BMG's extensive distribution network. It's through the sheer size and reach of our infrastructure, that BMG can be found wherever industry has established itself; delivering the correct components at the right time, to the far-flung coalface of our customers' operations.

- Over 300 000 product line items.
- Around 4 500 transfers per day out of BMG World in Johannesburg.
- Over 1 000 tons of imported stock landing per month.
- 88 strategically situated branches throughout Africa.
- Vendor Managed Inventory sites (dedicated on-site stockholding).
- International exports.
- Locally empowered distribution chains.

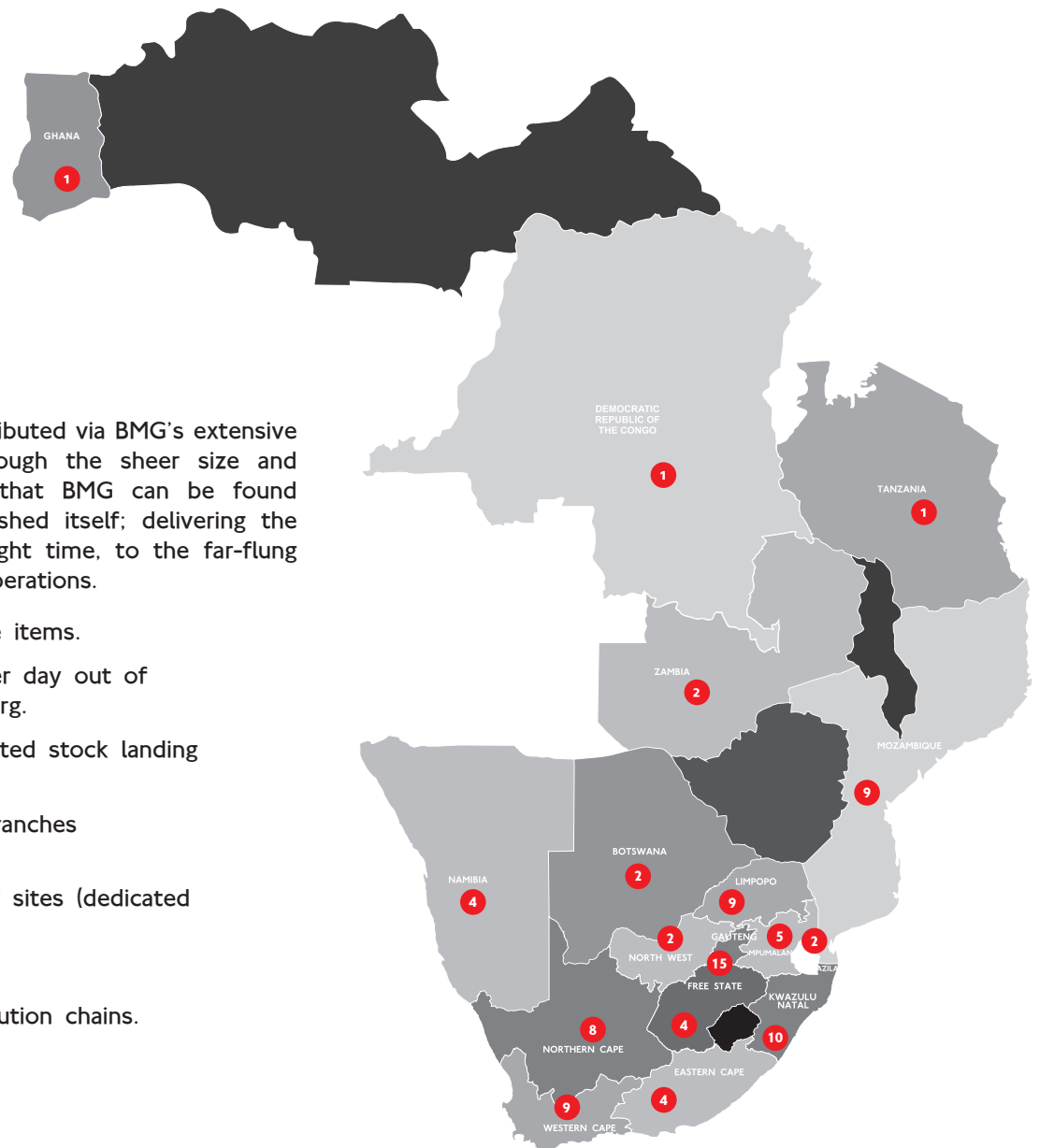

24 HR TOLL-FREE EMERGENCY  
BRANCH HELPLINE:

**0800 022 224**

WEBSITE:

**[www.bmgworld.net](http://www.bmgworld.net)**



An Invieta Holdings Group Company

BEARINGS • SEALS • POWER TRANSMISSION • DRIVES & MOTORS  
MATERIALS HANDLING • TOOLS & FASTENERS • HYDRAULICS  
FILTRATION • LUBRICATION • FIELD SERVICE