



AGRICULTURAL PRODUCT

Catalogue

Edition 4



B-BBEE 2

EMPOWERING SUPPLIER

ISO 9001	Certified
ISO 14001	Certified
ISO 45001	Certified

ABOUT US

Established in 1974 as a single bearing shop in Durban, South Africa; BMG's aggressive growth strategy has included acquisitions, supplemented by a steady organic growth discipline. BMG attracts best-of-breed talent resulting in technical expertise that differentiates BMG in the industry. Staff are truly part of the BMG family and its success.

BMG boasts an accredited in-house technical and commercial training academy which fosters a culture of staff development and career advancement; it's all about sustainability.

The net result, is a company that reliably supplies and supports 70 000 customers in 9 countries with the widest range of industrial engineered products and expert services in Africa via 88 branches.

BMG is positioned to deliver bespoke 360 degree solutions to its customers, and subsequently return on investment to its investors and shareholders. BMG plays a pivotal role in supporting the productivity and production targets of all Industrial, Manufacturing, Mining and Agricultural sectors of the economies in the countries it serves. With an enviable reputation as Africa's largest distributor, manufacturer and service provider of the highest quality engineering consumables and components; including

- Bearings & Seals
- Power Transmission Components
- Drives, Motors and Controllers
- Hydraulics, Pneumatics and Filtration
- Heavy and Light Duty Materials Handling
- Valves and Lubrication
- Fasteners, Gaskets and Tools

BMG is a level 2 BEE contributor with ISO 9001 Quality Assurance certification. Health and safety of its employees and customers is a paramount focus and the company adheres to ISO 45001. BMG is also committed to environmental care and sustainability and strictly follows the ISO 14001 charter.

As a key contributor to the Invicta Holdings stable, BMG has played a major part in Invicta's unique achievement of being rated in South Africa's Top 100 Companies for 21 consecutive years.



COUPLINGS

CONTENTS

Fenaflex Tyre Couplings - Dimensions	116
HRC Couplings Dimensions	117
Disc - Type Flexible Coupling	118

FENAFLEX TYRE COUPLINGS - DIMENSIONS

FLANGES

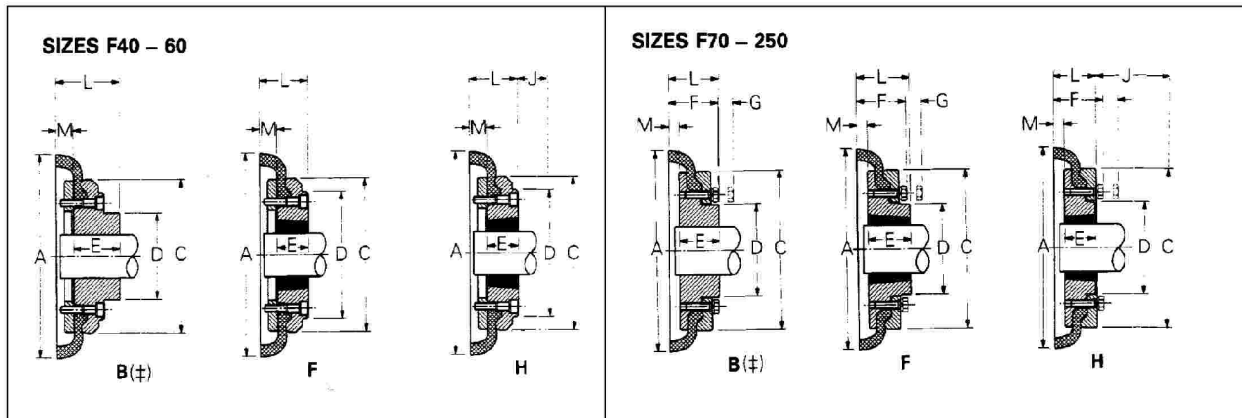

DIMENSIONS OF FENAFLEX FLANGES TYPES B, F & H

Size	Type	Bush No. #	Max Bore		Types F & H			Type B		Screw over Key	A	C	D	F	G§	M¶	Mass* (kg)	Inertia* (kgm ²)
			Metric	Inch	L	E	J†	L	E									
F40	B	-	32	-	-	-	29	33	22	M5	104	82	-	-	-	11	0,8	0,00074
F40	F	1008	25	1"	33	22	29	-	-	-	104	82	-	-	-	11	0,8	0,00074
F40	H	1008	25	1"	33	22	29	-	-	-	104	82	-	-	-	11	0,8	0,00074
F50	B	-	38	-	-	-	38	45	32	M5	133	100	79	-	-	12,5	1,2	0,00115
F50	F	1210	32	1 1/4"	38	25	38	-	-	-	133	100	79	-	-	12,5	1,2	0,00115
F50	H	1210	32	1 1/4"	38	25	38	-	-	-	133	100	79	-	-	12,5	1,2	0,00115
F60	B	-	45	-	-	-	38	55	38	M6	165	125	70	-	-	16,5	2,0	0,0052
F60	F	1610	42	1 5/8"	42	25	38	-	-	-	165	125	103	-	-	16,5	2,0	0,0052
F60	H	1610	42	1 5/8"	42	25	38	-	-	-	165	125	103	-	-	16,5	2,0	0,0052
F70	B	-	50	-	-	-	-	47	35	M10	187	144	80	50	13	11,5	3,1	0,009
F70	F	2012	50	2"	44	32	42	-	-	-	187	144	80	50	13	11,5	3,1	0,009
F70	H	1610	42	1 5/8"	42	25	38	-	-	-	187	144	80	50	13	11,5	3,0	0,009
F80	B	-	60	-	-	-	-	55	42	M10	211	167	98	54	16	12,5	4,9	0,018
F80	F	2517	60	2 1/2"	58	45	48	-	-	-	211	167	97	54	16	12,5	4,9	0,018
F80	H	2012	50	2"	45	32	42	-	-	-	211	167	98	54	16	12,5	4,6	0,017
F90	B	-	70	-	-	-	-	63,5	49	M12	235	188	112	60	16	13,5	7,1	0,032
F90	F	2517	60	2 1/2"	59,5	45	48	-	-	-	235	188	108	60	16	13,5	7,0	0,031
F90	H	2517	60	2 1/2"	59,5	45	48	-	-	-	235	188	108	60	16	13,5	7,0	0,031
F100	B	-	80	-	-	-	-	70,5	56	M12	254	216	125	62	16	13,5	9,9	0,055
F100	F	3020	75	3"	65,5	51	55	-	-	-	254	216	120	62	16	13,5	9,9	0,055
F100	H	2517	60	2 1/2"	59,5	45	48	-	-	-	254	216	113	62	16	13,5	9,4	0,054
F110	B	-	90	-	-	-	-	75,5	63	M12	279	233	128	62	16	12,5	12,5	0,081
F110	F	3020	75	3"	63,5	51	55	-	-	-	279	233	134	62	16	12,5	11,7	0,078
F110	H	3020	75	3"	63,5	51	55	-	-	-	279	233	134	62	16	12,5	11,7	0,078
F120	B	-	100	-	-	-	-	84,5	70	M16	314	264	143	67	16	14,5	16,9	0,137
F120	F	3525	100	4"	79,5	65	67	-	-	-	314	264	140	67	16	14,5	16,5	0,137
F120	H	3020	75	3"	65,5	51	55	-	-	-	314	264	140	67	16	14,5	15,9	0,130
F140	B	-	130	-	-	-	-	110,5	94	M20	359	311	178	73	17	16	22,2	0,254
F140	F	3525	100	4"	81,5	65	67	-	-	-	359	311	178	73	17	16	22,3	0,255
F140	H	3525	100	4"	81,5	65	67	-	-	-	359	311	178	73	17	16	22,3	0,255
F160	B	-	140	-	-	-	-	117	102	M20	402	345	187	78	19	15	35,8	0,469
F160	F	4030	115	4 1/2"	92	77	80	-	-	-	402	345	197	78	19	15	32,5	0,380
F160	H	4030	115	4 1/2"	92	77	80	-	-	-	402	345	197	78	19	15	32,5	0,380
F180	B	-	150	-	-	-	-	137	114	M20	470	398	200	94	19	23	49,1	0,871
F180	F	4535	125	5"	112	89	89	-	-	-	470	398	205	94	19	23	42,2	0,847
F180	H	4535	125	5"	112	89	89	-	-	-	470	398	205	94	19	23	42,2	0,847
F200	B	-	150	-	-	-	-	138	114	M20	508	429	200	103	19	24	58,2	1,301
F200	F	4535	125	5"	113	89	89	-	-	-	508	429	205	103	19	24	53,6	1,281
F200	H	4535	125	5"	113	89	89	-	-	-	508	429	205	103	19	24	53,6	1,281
F220	B	-	160	-	-	-	-	154,5	127	M20	562	474	218	118	20	27,5	79,6	2,142
F220	F	5040	125	5"	129,5	102	92	-	-	-	562	474	223	118	20	27,5	72,0	2,104
F220	H	5040	125	5"	129,5	102	92	-	-	-	562	474	223	118	20	27,5	72,0	2,104
F250	B	-	190	-	-	-	-	161,5	132	M20	628	532	254	125	25	29,5	104,0	3,505

Dimensions in millimetres unless otherwise stated.

§ G is the amount by which clamping screws need to be withdrawn to release tyre.

† J is the wrench clearance to allow for tightening/loosening the bush on the shaft and the clamp ring screws on sizes F40, F50 and F60. The use of a shortened wrench will allow this dimension to be reduced.

¶ M is half the distance between flanges. Shaft ends, although normally located twice M apart, can project beyond the flanges as shown. In this event allow sufficient space between shaft ends for end float and misalignment.

* Mass and inertia figures are for single flange with mid range bore and include clamping ring, screws and washers and half tyre.

‡ For pilot bore 'B' flange code as listed.

Flanges are also available finish bored with keyway if required.

Bore must be specified on order.

Note: On sizes F70, 80, 100 and 120 the 'F' direction bush is larger than that in the 'H' direction.

For Technical Specification refer to Fenner Catalogue

HRC COUPLINGS - DIMENSIONS

Example: Part No. = HRC70

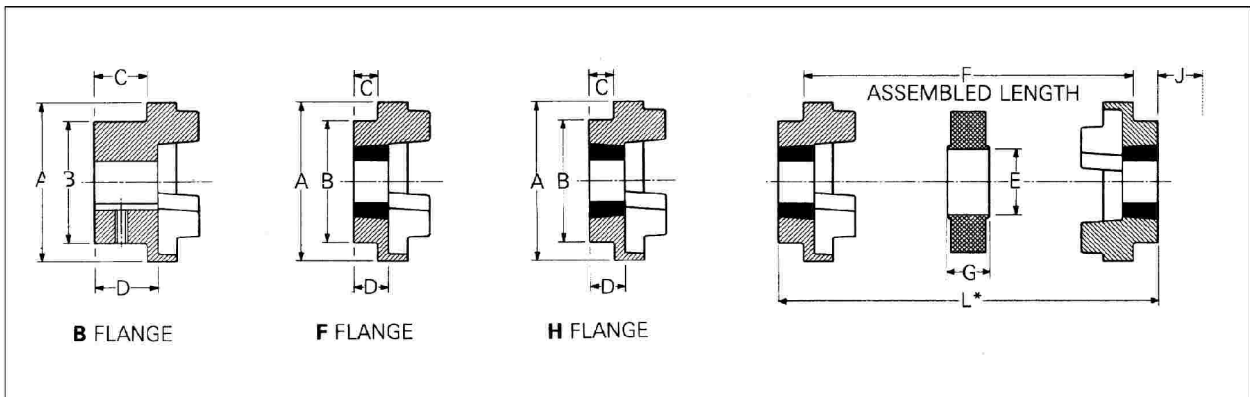

PHYSICAL DIMENSIONS AND CHARACTERISTICS

Size	Common Dimensions					Bush Size	Type F & H					Type B				
	A	B	E	F, ‡	G		Max. Bore		C	D	J†	Bore Dia's		Screw over key	C	D
							mm	ins.				Max.	Pilot H9			
70	69	60	31	25	18	1008	25	1"	20,0	23,5	29	32	8	M 6	20	23,5
90	85	70	32	30,5	22,5	1108	28	1 1/8	19,5	23,5	29	42	10	M 6	26	30
110	112	100	45	45	29	1610	42	1 5/8	18,5	26,5	38	55	10	M10	37	45
130	130	105	50	53	36	1610	42	1 5/8	18,0	26,5	38	60	15	M10	39	47,5
150	150	115	62	60	40	2012	50	2	23,5	33,5	42	70	20	M10	46	56
180	180	125	77	73	49	2517	60	2 1/2	34,5	46,5	48	80	25	M10	58	70
230	225	155	99	85,5	59,5	3020	75	3	39,5	52,5	55	100	25	M12	77	90
280	275	206	119	105,5	74,5	3525	100	4	51,0	66,5	67	115	30	M16	90	105,5

† 'J' is the wrench clearance required for tightening/loosening the bush on the shaft. A shortened wrench will allow this dimension to be reduced.
 ‡ F, refers to combinations of flanges: FF, FH, HH, FB, HB, BB.
 Bore limits H7 unless specified otherwise.

Size	Assembled Length (L*) Comprising Flange Types			Mass (kg)	Inertia Mr ² (kgm ²)	Dynamic Stiffness (Nm/°)	Maximum Misalignment		Nominal Torque (Nm)
	FF, FH, HH	FB, HB	BB				Parallel	Axial	
70	65	65	65	1,00	0,00085	-	0,3	+0,2	31
90	69,5	76	82,5	1,17	0,00115	-	0,3	+0,5	80
110	82	100,5	119	5,00	0,00400	65	0,3	+0,6	160
130	89	110	131	5,46	0,00780	130	0,4	+0,8	315
150	107	129,5	152	7,11	0,01810	175	0,4	+0,9	600
180	142	165,5	189	16,6	0,04340	229	0,4	+1,1	950
230	164,5	202	239,5	26,0	0,12068	587	0,5	+1,3	2000
280	207,5	246,5	285,5	50,0	0,44653	1025	0,5	+1,7	3150

All dimensions in millimetres unless otherwise stated.
 All HRC Elements have an angular misalignment capacity of up to 1°.
 Mass is for an FF, FH or HH coupling with mid range Taper-Lock Bushes.
 Standard element -40°C / +100°C.

For Technical Specification refer to Fenner Catalogue



DISC-TYPE FLEXIBLE COUPLING

TABLE 2: POWER RATING (kW)

Speed r/min	Disc-type coupling size							
	67	83	102	134	178	204	254	318
10	0.02	0.04	0.07	0.16	0.35	0.80	1.86	5.37
20	0.05	0.09	0.14	0.32	0.70	1.60	3.76	10.6
40	0.10	0.18	0.28	0.64	1.41	3.20	7.43	20.7
60	0.16	0.27	0.43	0.96	2.11	4.81	11.1	30.2
80	0.21	0.36	0.57	1.28	2.82	6.42	14.8	39.2
100	0.26	0.45	0.72	1.60	3.52	8.06	18.6	47.7
150	0.37	0.65	1.04	2.33	5.11	11.6	26.9	68.9
200	0.48	0.83	1.34	2.97	6.53	14.8	34.5	88.0
250	0.57	0.99	1.58	3.53	7.76	17.7	40.9	105.0
300	0.61	1.12	1.79	4.01	8.80	20.1	46.5	119.0
350	0.72	1.23	1.97	4.39	9.62	21.9	50.7	132.0
400	0.79	1.32	2.11	4.71	10.4	23.6	54.6	145.0
500	0.90	1.45	2.36	5.27	11.6	26.4	61.2	162.0
600	0.99	1.62	2.58	5.77	12.7	28.9	66.9	175.0
720	1.07	1.76	2.81	6.29	13.8	31.5	72.8	189.0
800	1.13	1.86	2.97	6.64	14.6	33.2	76.8	198.0
960	1.22	2.02	3.23	7.24	16.0	36.2	84.0	211.0
1000	1.24	2.06	3.30	7.39	16.3	36.9	85.8	214.0
1200	1.36	2.24	3.59	7.98	17.6	40.1	93.3	240.0
1400	1.46	2.40	3.83	8.58	18.8	42.8	99.2	261.0
1440	1.48	2.44	3.88	8.68	19.0	43.3	100.0	264.0
1600	1.57	2.60	4.07	9.10	20.0	45.5	105.0	274.0
1800	1.68	2.76	4.30	9.62	21.2	48.1	111.0	-
2000	1.80	2.95	4.51	10.2	22.4	50.7	-	-
2400	2.03	3.30	4.99	11.3	24.9	56.2	-	-
2880	2.29	3.74	5.54	12.7	27.9	60.6	-	-
3000	2.36	3.85	5.68	13.1	28.6	-	-	-
3600	2.73	4.39	6.37	14.8	-	-	-	-

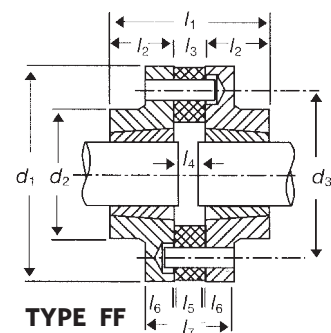
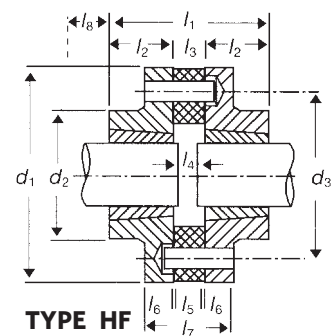
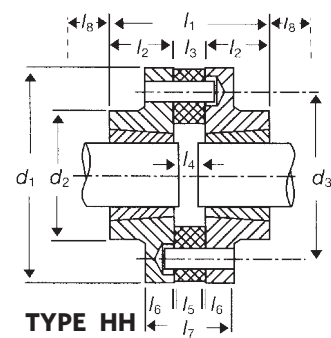

TABLE 3: DIMENSIONS

Size	Bush No.	Max. Bore Sizes mm	Mass kg	d ₁	d ₂	d ₃ Nom.	l ₁	l ₂	l ₃	l ₄	l ₅	l ₆	l ₇	l ₈	Pins per Flange	
															No.	Diam Nom
67	1108	28	1.2	67	-	51	58	22	14	+	11	22	58	29	3	8
83	1210	32	1.8	83	-	64	66	25	16	+	13	25	66	38	3	10
102	1210	32	2.5	102	67	76	66	25	16	+	13	14	44	38	4	10
134	1610	42	4.5	134	83	102	70	25	20	+	16	18	56	38	4	13
178	2517	60	10.2	178	124	143	108	44	20	+	16	22	67	48	5	16
204	2517	60	13.6	204	124	162	115	44	27	+	22	25	77	48	6	19
254	3020	75	34.9	254	152	197	139	51	37	+	32	35	107	54	6	25
318	3535	90	66.2	318	178	248	228	89	50	+	45	41	132	67	7	32

*l₈ = Wrench clearance to allow for tightening and loosening the bush on the shaft. The use of a shortened wrench will permit this dimension to be reduced.

+l₄= Shaft ends, although normally located dimension l₃ apart, can project beyond the flanges as shown. In this event, allow sufficient space between shaft ends for end float and misalignment. All couplings have an angular misalignment of 1°.

For Technical Specification refer to Fenner Catalogue



A large rectangular area containing 30 horizontal lines for writing notes.



BRINGING THE WORLD'S BEST BRANDS TO YOU

In the bid to procure cutting-edge components at competitive prices, BMG is able to capitalise on long-standing relationships with leading manufacturers dedicated to excellence in design and production.

Products are imported from around the globe and brought to BMG's strategically located distribution facilities and regional service centres via the main distribution hub in Johannesburg - BMG World. A world-class facility boasting 308 000m³ of fully stocked warehouse space, an accredited training facility and unlimited engineering capabilities.

Our Extensive Coverage Throughout Africa

88
BRANCHES

Products and services are distributed via BMG's extensive distribution network. It's through the sheer size and reach of our infrastructure, that BMG can be found wherever industry has established itself; delivering the correct components at the right time, to the far-flung coalface of our customers' operations.

- Over 300 000 product line items.
- Around 4 500 transfers per day out of BMG World in Johannesburg.
- Over 1 000 tons of imported stock landing per month.
- 88 strategically situated branches throughout Africa.
- Vendor Managed Inventory sites (dedicated on-site stockholding).
- International exports.
- Locally empowered distribution chains.

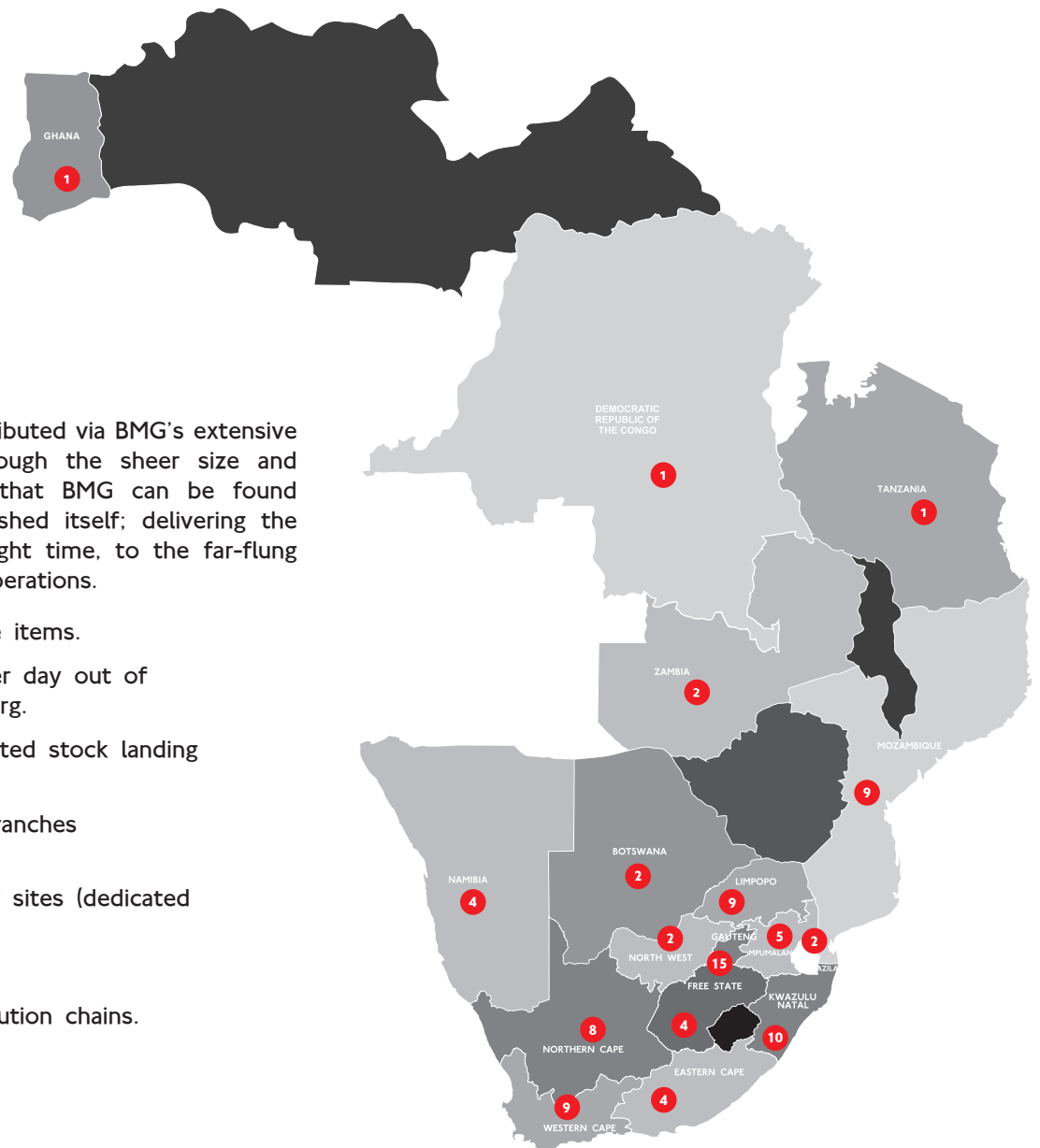

24 HR TOLL-FREE EMERGENCY
BRANCH HELPLINE:

0800 022 224

WEBSITE:

www.bmgworld.net



An Invieta Holdings Group Company

BEARINGS • SEALS • POWER TRANSMISSION • DRIVES & MOTORS
MATERIALS HANDLING • TOOLS & FASTENERS • HYDRAULICS
FILTRATION • LUBRICATION • FIELD SERVICE