



SYNERGY PLUS RANGE HIGH EFFICIENCY ELECTRIC MOTORS (IE3)

Technical Guide

B-BBEE 2
EMPOWERING SUPPLIER

ISO 9001	Certified
ISO 14001	Certified
ISO 45001	Certified

ABOUT US

Established in 1974 as a single bearing shop in Durban, South Africa; BMG's aggressive growth strategy has included acquisitions, supplemented by a steady organic growth discipline. BMG attracts best-of-breed talent resulting in technical expertise that differentiates BMG in the industry. Staff are truly part of the BMG family and its success.

BMG boasts an accredited in-house technical and commercial training academy which fosters a culture of staff development and career advancement; it's all about sustainability.

The net result, is a company that reliably supplies and supports 70 000 customers in 9 countries with the widest range of industrial engineered products and expert services in Africa via 98 branches.

BMG is positioned to deliver bespoke 360 degree solutions to its customers, and subsequently return on investment to its investors and shareholders. BMG plays a pivotal role in supporting the productivity and production targets of all Industrial, Manufacturing, Mining and Agricultural sectors of the economies in the countries it serves. With an enviable reputation as Africa's largest distributor, manufacturer and service provider of the highest quality engineering consumables and components; including

- Bearings & Seals
- Power Transmission Components
- Drives, Motors and Controllers
- Hydraulics, Pneumatics and Filtration
- Heavy and Light Duty Materials Handling
- Valves and Lubrication
- Fasteners, Gaskets and Tools

BMG is a level 2 BEE contributor with ISO 9001 Quality Assurance certification. Health and safety of its employees and customers is a paramount focus and the company adheres to ISO 45001. BMG is also committed to environmental care and sustainability and strictly follows the ISO 14001 charter.

As a key contributor to the Invicta Holdings stable, BMG has played a major part in Invicta's unique achievement of being rated in South Africa's Top 100 Companies for 21 consecutive years.





Registration number: 2022/410870/07

THIS PRODUCT CERTIFICATION PERMIT AUTHORIZES

Bearing Man Group (Pty) Ltd t/a BMG

Company reg. Number: 2014/147732/07
C/O FUZHOU WONDER ELECTRIC CO., LTD.

120 Changyang road. Chang an Investment District Fuzhou, CHINA

To apply the Product certification mark of ExCS, illustrated below,



to the Manufacture and Supply of certified equipment in compliance with the requirements of the Product certification Agreement of ExCS and the requirements of the following standard specifications:

- **SANS 1804-1:2012** Induction motors Part 1: IEC requirements
- **SANS 1804-2: 2012** Induction motors Part 2: Low-voltage three-phase standard motors

PRODUCT CERTIFICATION PERMIT NUMBER: **EXP013A**

This permit consists of the official Product certification permit (front page) and Annexure A – Scope of permit. This Product certification permit, including the Annexure A, which forms part of the official Product certification permit, applies to following conditions:

- ❖ The product certification permit & Annexure A, is issued without alteration
- ❖ Is identified by the applicable permit number
- ❖ Is only valid, subject to ongoing compliance with the permit conditions
- ❖ This permit may not be distributed without a copy of the latest and valid Annexure A – Scope of permit, is accompanied.
- ❖ This Product certification permit may be authenticated by referring to the “Certified Clients” list on the website of Explolabs. (www.explolabs.co.za)

DIRECTOR

Effective Date:	18 July 2023
Expiry Date:	17 July 2026
Original registration date:	18 July 2023



Explolabs Certification Services (Pty) Ltd.
Reg. No: 2022/410870/07

Directors: R. Venter (M.D) & D. Maree
No. 7 Spanner Road, Olifantsfontein Johannesburg, South Africa
Tel: +27 (11) 316 4601 :: Cell: +27(0) 78 837 5767
Website: explolabs.co.za :: Email: ranterv@explolabs.co.za

BMG SYNERGY IE3

Three Phase High Efficiency Asynchronous Cast Iron Motors

BMG's Synergy range of asynchronous motors are designed to comfortably comply with the efficiency requirements as stipulated in SANS 60034 30:2009. An oversized terminal box with removable gland plate were added to ease motor installation.



Characteristics for all BMG standard 3-phase asynchronous motors

- Widely used in general machinery and industries such as pumps & water treatment, mining, petroleum, chemical, metallurgy, cement, sugar and paper milling.
- IP66 protection, class H insulation, B (80°C) temperature rise, S1-duty,
- Rated Voltage: 400V and 525V, Rated Frequency: 50Hz
- Operating Conditions Ambient Temperature: -20°C ~ 40°C, Voltage ±10%, Altitude tested at SABS at 1330 m.
- Y-connection for motors of up to 3kW and Δ-connection for 4kW and above
- The Cooling method is IC411.
- Star/delta starting for motors 4kW and larger.
- Type test certification is available on request.

Mounting Arrangements

Types	Basic Type of Construction	Derived Types of Construction				
80-355	IM B3 IM 1001 	IM V5 IM 1011 	IM V6 IM 1031 	IM B6 IM 1051 	IM B7 IM 1061 	IM 88 IM 1071
80-355	IM B35 IM 2001 	IM V15 IM 2011 	IM V36 IM 2031 	• IM 2051 	• IM 2061 	• IM 2071
80-160	IM B34 IM 2101 	• IM 2111 	• IM 2131 	• IM 2151 	• IM 2161 	• IM 2171
80-355	IM B5 IM 3001 	IM V1 IM 3011 	IM V6 IM 3031 			
80-160	IM B14 IM 3601 	IM V18 IM 3611 	IM V19 IM 3631 			

Basic types of construction may be used in all derived types of construction (*) not-defined mounting by IEC 60034-7

1) For the construction types IM V6, IM B6, IM 88 inquiry is necessary.

Standard 3-phase motors can be connected using the star or delta method.

The star connection is achieved by wiring W2, U2, V2 to each other; and U1, V1, W1 leads to voltage supply.

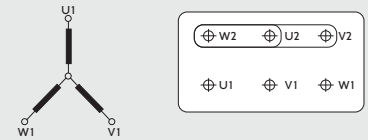

The delta connection is achieved by wiring the end of a phase to the head of another.

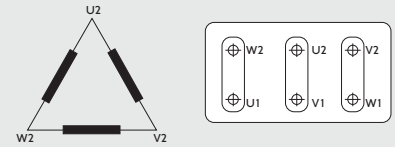

Star-delta (Y/Δ) Starting:

Most low voltage motors are delta wired to operate at 400V and star wired to operate at 690V. This flexibility can also be used to operate the motor under lower voltages. Apart from the fact that startup current in star-delta starting drops to one third of direct starting, the startup moment also decreases by around 25%. The motor is started in the star connection and accelerated as much as possible, then it is transferred to the delta connection. This method can only be used in asynchronous motors which are delta-connected to supply voltage.

Voltage / 60Hz

Motors are normally designed for 400V, 50Hz. Other voltages and 60Hz frequency are optional. Our motors wound for 50Hz can be operated at 60Hz for the same output power. The ratios given below indicate changes in the given parameters.

60Hz Application Coefficients of 50Hz Motors								
50Hz Voltage	60Hz Application	Rated Speed	Rated Power	Rated Torque	Rated Current	Starting Torque	Breakdown Torque	Starting Current
220V	220V	1.2	1	0.83	1	0.83	0.83	0.83
220V	255V	1.2	1.15	0.96	1	0.96	0.96	0.96
380V	380V	1.2	1	0.83	1	0.70	0.83	0.83
380V	440V	1.2	1.15	0.96	1	0.95	0.98	0.97

TECHNICAL INFORMATION

Insulation Classification

The Synergy motor has a class H insulation with a class B (80°C) temperature rise, ensuring a longer service life.

Under specified measuring conditions in accordance with IEC 60034-1 standard, insulation class H for an electric motor means that at an ambient temperature of 40°C, the temperature rise of its windings may be a max. of 125K with the additional temperature margin of 15K.

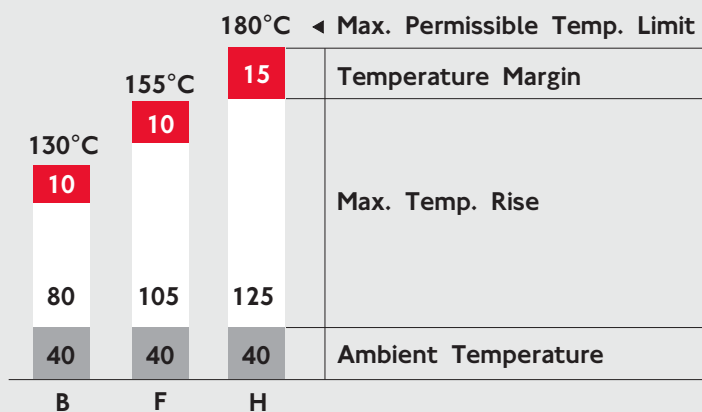

Degree of Protection

According to IEC 60034-5 standard, electric motors are provided with IP an code which determines the degree of protection ensured the motor against access to dangerous parts, introducing foreign matter and/or water.

Our motors comply with the IP66 protection class as a standard.

Contact us for additional classes.

The First Characteristic numeral: Protection from ingress of solid foreign matter		The second characteristic Numeral: Protection against penetration of water and it's harmful effects	
0	Non-protected Machine	Non-protected Machine	0
1	The machine is protected against solid objects greater than 50 mm	The Machine is protected against dripping water	1
2	The machine is protected against solid objects greater than 12 mm	The Machine is protected against dripping water when tilted up to 15°	2
3	The machine is protected against solid objects greater than 2.5 mm	The Machine is protected against spraying water	3
4	The machine is protected against solid objects greater than 1 mm	The Machine is protected against splashing water	4
5	A Dust Protected Machine	The Machine is protected against water jets	5
6	A Dust-tight Machines	The Machine is protected against heavy seas	6

Electronic Soft Starters

Through the use of an electronic soft starter, which controls parameters such as current and voltage, the starting sequence can be totally controlled. The starter can be programmed to limit the amount of starting current where, by limiting the rate of the current increase, the startup time can be extended.

VSD Drives

The Synergy motor performs excellently without cogging at low speed when operating in conjunction with a VSD. VSD's are primarily recognised for their ability to manipulate power from a constant 3-phase 50/60Hz supply, converting it to variable voltage and variable frequency power.

This enables the speed of the motor to be matched to its load in a flexible and energy efficient manner. The only way of producing starting torque equal to full load torque with full load current is by using a VSD. The functionally flexible VSD is also commonly used to reduce energy consumption on fans, pumps and compressors and offer a simple and repeatable method of changing speeds or flow rates.

For operation below 30Hz, motor cooling fan efficiency drops significantly. Hence, in the constant torque applications, a force cooling fan should be fitted to provide sufficient cooling of the motor.

For an operation above 50Hz, all Synergy motors are capable of delivering constant rated power up to 60Hz. However, most of these motors are suitable to run and deliver constant power at much higher frequencies than 60Hz to a maximum of 100Hz. In the case of applications between 60Hz and 100Hz please contact BMG for advice on suitability.

The Synergy range of motors will operate without modification on VSD however under certain conditions additional features should be considered (See EDM concerns below). The graph below shows the Synergy motor's loadability with a frequency converter.

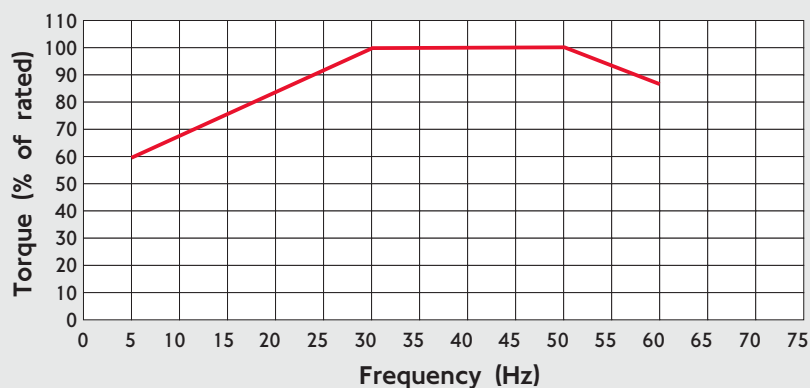

EDM Concerns

Capacitive voltages in the rotor can be generated due to an effect caused by harmonics in the waveform causing voltage discharge to earth through the bearings. This discharge results in etching of the bearing running surfaces. This effect is known as Electrical Discharge Machining (EDM). It can be controlled with the fitment of appropriate filters to the drive.

To further reduce the effect of EDM, and insulated non drive bearing can be used. BMG recommends the use of insulated bearings for all motors 315 frame and above.

Thermal Protection

Resistance Temperature Detectors (RTDs) and additional thermistors can be installed in both the windings and the bearings.

Thermistors

Synergy motors are fitted, as a standard, with one set (3) of PTC thermistors, selected for a tripping temperature of 145°C. These thermo-variable resistors have a positive temperature coefficient and fitted per phase in the motor windings.

RTDs

An additional way of monitoring temperature is to fit PT100 Resistance Temperature Detectors (RTDs). These devices have a linear temperature/resistance gradient and can be used in conjunction with electronic control equipment e.g. PLC's. Winding RTDs are optional.

Torque Characteristics

Typical characteristics of torque behaviour relative to speed, are shown in the torque speed curve example below. Synergy motors all exceed the minimum starting torque requirements for design N (normal torque) as specified in IEC 60034-12 and AS1359.41. Full load torque can be calculated with the following formula:

$$T_N = \frac{9550 \times P_N}{n_N}$$

Where:

T_N = Full Load Torque (Nm)

P_N = Full Load Power (kW)

n_N = Full Load Speed (r/min)

T_L = Locked Rotor Torque

T_U = Pull-up Torque

T_B = Break Down Torque

n_s = Synchronous Speed

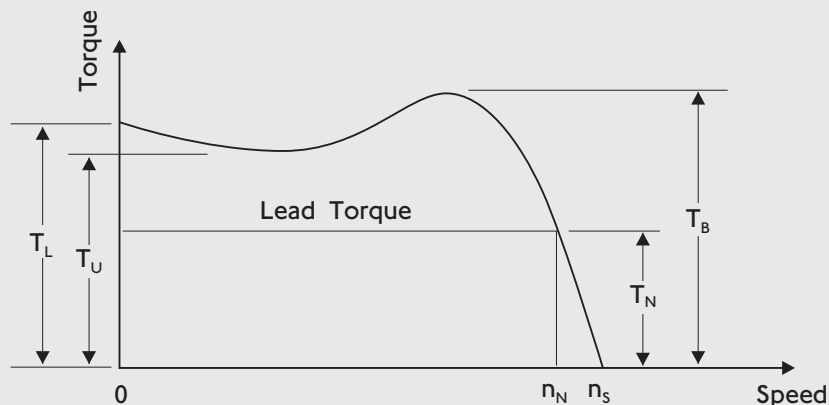

Lifting Lugs

Motor sizes 90-132, 315 and up are supplied with lifting lugs coated in zinc plated steel. Motor sizes 160-280 have lugs as a casted part of the stator frame. Motor sizes 160 and up, the housing has a minimum of 2 lifting lugs placed opposite each other. One lug mounted and one supplied loose, secured inside the crate before delivery (if the lug is a casted part of the frame, not loose in the box).



Terminal Box

As a standard the terminal box is located on the top in the D-end in accordance IEC 60034-7. The terminal box is secured to the motor housing with 4 screws with a cross notch or hexagon head. One screw is brass and three screws are galvanized steel grade 8.8. The brass



screw will function as the current overload protector in case of terminal malfunction, or loose supply voltage wire in accordance with marine regulations. All screws are in accordance with DIN standards.

An earth terminal shall be provided inside and outside the terminal box. Terminal boxes can rotate 90°, allowing cable entry from all directions. Motor frame 280 and above can have additional terminal boxes for accessories leads attached. FL terminal boxes are available for frame sizes 160-355, which is very convenient for industrial cable connection.

Drain Holes

Synergy standard motors are designed with drain holes to lead out condensed water. The drain holes are closed with stainless steel one way valve to comply with protection degree IP66. The drain hole can be in the stator housing or in the flange/end shield, and always at the lowest point.

Bearings

Synergy motors are supplied with ball bearings as a standard for all 2 pole motors up to frame size 450. For frame size 315 and above with 4 poles, NU bearings are supplied as a standard. NU bearings are optional for frames size 160-280. For special applications, the bearing may be larger or be an angular contact bearings (on request). All bearings are of SKF, NTN or NSK brand. All motors are with locked bearings in the D-end. Motor size 80 with circlips, size 90-132 with a Galvanized Steel cover and motor size 160-355 with a bearing cover. The bearing is fixed with a circlip onto the shaft in motor sizes 160 and above. In front of the ND-end bearing, a spring washer is mounted to make a proper preload of the bearings and minimise the shaft migration. Synergy motors are supplied with open bearings and grease nipples for frame sizes 160 and above. Motors from frame sizes 80-132 have a life-time of lubricated bearings. All standard lubrication nipples are in Brass or Stainless Steel, suitable for all environments.

Surface Treatment

Surface roughness of all visible surfaces on the motor is from 50 to 125 microns. All the motor parts are painted, as well as the inside fan cover and chamfer on the B5 and B14 flange. Shaft and flange mounting faces are without paint, but are protected from corrosion with an oil product.



The Synergy IE3 motor comes standard as black with a red cowl.

The paint type and layer thickness makes the motors suitable for environment category C3 in accordance with EN ISO 12944:1998 suitable for both marine and industrial applications.

Bearing Monitoring Device

SPM can be installed for continuous monitoring of bearing operation temperature. This device is critical in some applications because it directly affects the grease and bearing life. **SPM holes are provided for all motor frame sizes and SPM is an optional on request.** For more information please contact your nearest BMG branch.

Packaging

All Synergy motors are delivered in robust packaging, according to our packing standards. The shaft is fixed against axial movement during transportation for motors with roller bearings, angular bearings and standard motor sizes 280 and above. Frame sizes below 160 are packed in carton boxes, while 160 and above are packed in wooden crates. International standard pallets are used for packaging and shipment.



Terminal Box (Removable Gland Plate from Frames 132 and Above)

Frame Size	Thread of Cable Gland (mm)	Overall Dimensions (mm)
80-100	1-M25x1.5	124x100x50
112-132	2-M32x1.5	150x124x60
160-180 < 200	2-M40x1.5	200x160x80
225	2-M50x1.5	250x200x92
250-280	2-M63x1.5	340x210x106
315	2-M63x1.5	413x258x165
355	2-M63x1.5	461x300x190

Bearings

Frame Size	Driving End		Non-Driving End	
	2 Pole	4,6,8 Pole	2 Pole	4,6,8 Pole
80	6205 2Z/C3	6205 2Z/C3	6205 2Z/C3	6205 2Z/C3
90	6206 2Z/C3	6206 2Z/C3	6206 2Z/C3	6206 2Z/C3
100	6206 2Z/C3	6206 2Z/C3	6206 2Z/C3	6206 2Z/C3
112	6207 2Z/C3	6207 2Z/C3	6207 2Z/C3	6207 2Z/C3
132	6208 2Z/C3	6208 2Z/C3	6208 2Z/C3	6208 2Z/C3
160	6209 2Z/C3	6209 2Z/C3	6209 2Z/C3	6209 2Z/C3
180	6211/C3	6311/C3	6211/C3	6211/C3
200	6212/C3	6312/C3	6212/C3	6212/C3
225	6312/C3	6313/C3	6312/C3	6312/C3
250	6313/C3	6314/C3	6313/C3	6313/C3
ZWE250/75kW	6314/C3	6315/C3	6313/C3	6313/C3
280	6314/C3	6317/C3	6314/C3	6314/C3
ZWE280/110kW	6314/C3	6319/C3	6314/C3	6314/C3
315	6317/C3	NU319	6317C3/7317B(V1)	6319C3/7319B(V1)
355	6319/C3	NU322	6319C3/7319B(V1)	6322/7322B(V1)

The above motors can be loaded directly.

NU bearings are recommended in cases of high radial force.

Regreasing

Type	Maximum Relubrication Intervals				Regreasing Quantity (g)
	2 Pole	4 Pole	6 Pole	8 Pole	
WE160-180/B3	3400	7000	9000	10000	30
WE160-180/B35					
WE160-180/B5					
WE160-180/V1	1700	3500	4500	5000	50
WE200-225/B3	2400	6200	8200	9500	
WE200-225/B35					
WE200-225/B5	1200	3100	4100	4750	70
WE200-225/V1					
WE250-280/B3					
WE250-280/B35					
WE250-280/B5	1100	2400	3200	4000	100
WE250-280/V1					
WE315-355/B3					
WE315-355/B35					
WE315-355/V1	500	1500	2500	3200	

TECHNICAL INFORMATION

IE3 Synergy Motor 6 Pole 1000 r/min

Frame	Rated Power	Rated Speed	Rated Current A		Rated Torque	Efficiency % of Full Load			Power Factor % of Full Load			Locked Current	Locked Torque	Maximum Torque	Noise Level	Moment Inertia	Mass
	kW	r/min	400V	525V	Nm	50%	75%	100%	50%	75%	100%	IL/IN	TL/TN	Tmax/TN	Db (A)	J (kg/m ²)	kg
90S	0.75	940	1.93	1.47	7.62	76.0	79.0	78.9	0.55	0.64	0.71	4.38	2.23	2.49	45	0.00321	24
90L	1.1	950	2.76	2.10	11.06	79.0	79.3	81.0	0.55	0.64	0.71	5.77	2.82	2.93	45	0.00412	26
100L	1.5	955	3.55	2.70	14.92	81.1	82.4	82.5	0.58	0.72	0.74	5.24	2.27	2.61	46	0.00845	34
112M	2.2	960	5.02	3.83	21.89	83.1	84.7	84.3	0.58	0.70	0.75	5.12	2.11	2.44	46	0.01326	40
132S	3	965	6.74	5.14	29.69	84.4	85.9	85.6	0.59	0.70	0.75	5.38	2.09	2.44	50	0.03716	57
132M	4	970	8.8	6.67	39.38	85.2	86.9	86.8	0.58	0.70	0.76	5.95	2.42	2.60	50	0.04889	73
132M	5.5	970	11.9	9.0	54.15	86.5	88.1	88.0	0.58	0.70	0.76	6.34	2.30	2.66	53	0.0585	77
160M	7.5	975	15.7	12.0	73.5	87.9	89.1	89.1	0.58	0.70	0.77	6.40	2.51	2.81	56	0.1130	139
160L	11	975	22.8	17.4	108	89.2	90.3	90.3	0.58	0.70	0.77	7.42	2.45	2.84	56	0.1600	139
180L	15	980	29.7	22.9	146	89.8	91.2	91.2	0.64	0.74	0.80	8.49	2.75	3.36	59	0.370	189
200L	18.5	980	36.4	27.7	180	90.8	91.8	91.7	0.68	0.77	0.80	8.27	2.99	3.18	59	0.380	231
200L	22	980	43.1	32.8	214	91.1	92.2	92.2	0.67	0.76	0.80	8.58	2.18	3.45	59	0.440	240
225M	30	985	56.2	42.8	291	92.6	93.2	92.9	0.72	0.80	0.83	6.94	2.12	2.58	61	0.711	305
250M	37	980	68.1	51.9	361	92.4	93.4	93.3	0.78	0.85	0.84	8.37	2.91	3.10	61	1.213	390
250S	45	985	81.6	62.1	436	92.6	93.6	93.7	0.78	0.84	0.85	8.37	2.90	2.91	66	1.750	485
280M	55	985	99	76	533	93.2	94.1	94.1	0.81	0.86	0.85	8.52	2.12	3.32	66	1.990	562
280M	75	980	134	102	731	92.9	94.3	94.6	0.77	0.83	0.85	6.83	1.88	2.75	70	3.860	612
315M	90	990	159	121	868	93.0	94.4	94.9	0.77	0.85	0.86	7.03	2.12	2.81	70	4.950	955
315L	110	990	195	149	1061	94.0	95.0	95.1	0.79	0.84	0.86	7.11	2.01	2.70	70	5.760	1135
315L	132	990	234	178	1273	94.3	95.2	95.4	0.79	0.84	0.85	7.59	2.13	2.84	72	5.790	1205
355M	160	990	277	211	1543	94.4	95.5	95.8	0.79	0.86	0.87	7.29	2.35	2.84	75	9.960	1765
355M	200	990	346	264	1929	94.7	95.6	95.8	0.80	0.86	0.87	7.37	2.45	2.82	75	11.500	1905
355L	250	990	433	330	2412	94.7	95.6	95.8	0.80	0.86	0.87	7.53	2.55	2.83	75	12.600	1963
355L	275	990	476	363	2653	94.9	95.6	95.8	0.78	0.85	0.87	7.55	2.57	2.90	75	13.000	2020

IE3 Synergy Motor 8 Pole 50 r/min

Frame	Rated Power	Rated Speed	Rated Current A		Efficiency % of Full Load			Power Factor % of Full Load			Locked Current	Locked Torque	Maximum Torque	Noise Level	Moment Inertia	Mass
	kW	r/min	400V	525V	50%	75%	100%	50%	75%	100%	IL/IN	TL/TN	Tmax/TN	Db (A)	J (kg/m ²)	kg
90S	0.37	710	1.36	1.03	66.2	69.1	70.4	0.45	0.50	0.57	6.5	2.0	2.0	45	0.0033	22
90L	0.55	710	1.90	1.45	71.7	72.1	73.9	0.45	0.51	0.58	6.5	2.0	2.0	45	0.0043	24
100L	0.75	715	2.37	1.81	75.0	76.1	76.4	0.47	0.55	0.60	6.8	2.0	2.1	47	0.0069	31
100L	1.1	720	3.32	2.53	76.6	78.5	78.8	0.48	0.56	0.61	7.0	2.0	2.1	47	0.0103	32
112M	1.5	720	4.16	3.17	79.5	80.1	80.7	0.53	0.60	0.65	7.0	2.0	2.1	49	0.013	38
132S	2.2	725	5.77	4.40	82.2	83.4	82.8	0.55	0.61	0.66	7.0	2.0	2.2	50	0.034	55
132M	3.0	725	7.70	5.87	82.5	83.9	84.3	0.55	0.62	0.67	7.2	2.2	2.3	50	0.042	71
160M	4.0	725	9.41	7.17	83.1	85.2	85.6	0.56	0.66	0.72	7.2	2.1	2.2	53	0.0889	103
160M	5.5	730	12.5	9.5	85.2	87.1	87.0	0.56	0.67	0.73	6.0	2.1	2.2	53	0.0958	114
160L	7.5	730	16.8	12.8	86.3	88.1	88.2	0.56	0.67	0.73	6.0	2.0	2.2	53	0.1021	136
180L	11	730	24.4	18.6	87.8	89.3	89.6	0.56	0.68	0.73	6.0	2.0	2.3	53	0.2275	193
200L	15	735	32.4	24.7	89.1	90.3	90.6	0.57	0.68	0.74	6.6	2.0	2.3	55	0.395	246
225S	18.5	735	39.0	29.7	89.7	91.3	91.2	0.58	0.69	0.75	6.6	1.9	2.0	55	0.603	288
225M	22	735	46.1	35.1	89.8	91.8	91.7	0.58	0.69	0.75	6.6	1.9	2.0	55	0.698	310
250S/M	30	735	60.7	46.3	91.1	92.6	92.5	0.60	0.71	0.77	6.6	1.9	2.0	58	0.983	395
250S/M	37	735	73.8	56.2	91.2	92.8	93.0	0.63	0.72	0.78	6.6	1.9	2.2	58	1.857	515
280S/M	45	735	89.4	68.1	91.7	93.1	93.4	0.63	0.73	0.78	6.6	1.9	2.2	58	1.998	570
280S/M	55	740	106	81.0	92.2	93.4	93.8	0.65	0.75	0.78	6.6	1.9	2.0	63	4.959	965
315M	75	740	144	110	92.6	93.8	94.3	0.65	0.75	0.80	6.6	1.8	2.0	63	5.825	1030
315M/L	90	740	170	130	92.8	94.1	94.6	0.65	0.75	0.80	6.6	1.8	2.0	63	6.753	1120
315M/L	110	740	208	158	93.1	94.4	94.9	0.65	0.75	0.81	6.4	1.8	2.0	63	7.352	1205
355M/L	132	745	245	187	93.2	94.7	95.1	0.68	0.78	0.81	6.4	1.8	2.0	70	12.94	1865
355M/L	160	745	296	226	93.5	95.0	95.4	0.68	0.78	0.82	6.4	1.8	2.0	70	13.32	1965
355M/L	200	745	369	281	93.6	95.3	95.6	0.68	0.78	0.82	6.4	1.8	2.0	70	14.9	2130

Premium Efficiency Motors IEC60034-30, IE3 code
Efficiency Testing Method IEC60034-2-1, 2007

TECHNICAL INFORMATION

IE3 Synergy Motor 2 Pole 3000 r/min

Frame	Rated Power	Rated Speed	Rated Current A		Rated Torque	Efficiency % of Full Load			Power Factor % of Full Load			Locked Current	Locked Torque	Maximum Torque	Noise Level	Moment Inertia	Mass
	kW	r/min	400V	525V	Nm	50%	75%	100%	50%	75%	100%	IL/IN	TL/TN	Tmax/TN	Db (A)	J (kg/m ²)	kg
80M	0.75	2890	1.61	1.23	2.48	79.2	80.6	80.7	0.61	0.74	0.83	7.05	3.16	3.32	61	0.00110	18
80M	1.1	2885	2.31	1.76	3.64	81.0	82.5	82.7	0.71	0.76	0.83	7.76	2.71	3.41	62	0.00157	20.5
90S	1.5	2890	2.99	2.28	4.96	83.1	83.9	84.2	0.73	0.81	0.86	7.42	2.74	3.12	62	0.00185	29.5
90L	2.2	2905	4.30	3.27	7.23	85.1	86.4	85.9	0.76	0.83	0.86	8.32	3.33	3.54	63	0.00345	36.5
100L	3.0	2920	5.78	4.40	9.81	86.7	87.7	87.1	0.71	0.79	0.86	8.19	2.90	3.52	63	0.00425	37
112M	4.0	2920	7.36	5.61	13.1	87.8	88.8	88.1	0.78	0.85	0.89	7.83	2.39	3.30	63	0.00650	46
132S	5.5	2920	10.0	7.62	18.0	88.1	89.3	89.2	0.79	0.86	0.89	7.50	2.07	3.53	66	0.01799	63
132S	7.5	2920	13.5	10.3	24.5	88.7	89.8	90.1	0.80	0.86	0.89	7.96	2.25	3.59	66	0.02272	70
160M	11	2945	19.8	15.1	35.7	89.4	91.0	91.2	0.84	0.89	0.88	8.29	2.51	3.06	69	0.0660	113
160M	15	2945	26.5	20.2	48.6	90.7	91.9	91.9	0.85	0.90	0.89	8.32	2.58	2.93	69	0.0680	124
160L	18.5	2945	32.5	24.7	60.0	91.3	92.4	92.4	0.83	0.88	0.89	8.47	2.54	3.06	70	0.0760	141
180M	22	2955	37.9	28.9	71.1	90.8	92.4	92.7	0.82	0.88	0.90	8.48	2.53	3.65	70	0.1730	177
200L	30	2955	51.6	39.3	97.0	91.5	92.8	93.3	0.86	0.90	0.90	8.39	2.60	3.37	75	0.193	224
200L	37	2960	62.6	47.7	119	92.6	93.7	93.7	0.87	0.90	0.91	8.65	2.90	3.51	75	0.203	240
225M	45	2965	76.0	57.9	145	92.1	93.6	94.0	0.86	0.90	0.91	8.44	2.52	3.32	76	0.411	345
250M	55	2965	93.5	71.3	177	92.3	93.9	94.3	0.86	0.91	0.90	8.37	2.50	3.26	78	0.435	391
250M	75	2980	127	96.8	240	92.7	94.2	94.7	0.85	0.89	0.90	7.52	2.29	3.06	80	0.743	430
280M	90	2980	152	116	288	93.2	94.6	95.0	0.86	0.90	0.90	7.53	2.22	3.02	80	0.823	550
280M	110	2980	185	141	353	92.9	94.5	95.2	0.84	0.90	0.90	7.72	2.18	3.59	81	1.640	600
315M	132	2980	222	169	423	93.3	94.8	95.4	0.85	0.90	0.90	7.98	2.31	3.58	81	1.780	985
315L	160	2980	268	205	513	93.6	95.1	95.6	0.85	0.90	0.90	7.88	2.17	3.35	82	1.970	1100
315L	200	2980	335	255	641	94.2	95.4	95.8	0.85	0.90	0.90	8.15	2.39	3.41	83	2.310	1200
355M	250	2980	414	315	801	93.8	95.2	95.8	0.88	0.89	0.91	7.60	1.85	3.03	85	3.900	1725
355L	275	2985	455	347	880	94.1	95.3	95.8	0.85	0.89	0.91	7.16	1.93	3.02	85	4.010	1870
355L	315	2980	523	398	1009	93.8	95.2	95.8	0.89	0.91	0.91	7.46	2.07	3.18	85	4.030	1930

IE3 Synergy Motor 4 Pole 1500 r/min

Frame	Rated Power	Rated Speed	Rated Current A		Rated Torque	Efficiency % of Full Load			Power Factor % of Full Load			Locked Current	Locked Torque	Maximum Torque	Noise Level	Moment Inertia	Mass
	kW	r/min	400V	525V	Nm	50%	75%	100%	50%	75%	100%	IL/IN	TL/TN	Tmax/TN	Db (A)	J (kg/m ²)	kg
80M	0.75	1425	1.73	1.32	5.03	80.2	81.5	82.5	0.57	0.70	0.76	6.20	3.09	3.44	48	0.00165	20.5
90S	1.1	1450	2.39	1.82	7.24	83.7	84.0	84.1	0.61	0.73	0.79	7.04	3.10	3.43	50	0.00232	25.5
90L	1.5	1450	3.25	2.48	9.88	84.4	84.9	85.3	0.65	0.76	0.78	7.32	3.13	3.45	52	0.00312	28.5
100L	2.2	1455	4.58	3.49	14.44	85.6	86.8	86.7	0.63	0.74	0.80	8.00	2.53	3.37	52	0.00790	35
100L	3.0	1450	6.02	4.59	19.76	87.2	87.7	87.7	0.65	0.75	0.82	7.59	2.94	3.19	52	0.00865	41
112M	4.0	1460	7.85	5.98	26.2	87.4	88.4	88.6	0.72	0.77	0.83	7.66	2.16	2.98	56	0.01850	45
132S	5.5	1465	10.8	8.23	35.9	87.8	89.5	89.6	0.67	0.77	0.82	7.00	2.33	3.05	56	0.04392	66
132M	7.5	1465	14.4	11.0	48.9	88.7	90.3	90.4	0.69	0.79	0.83	7.42	2.55	3.09	56	0.05857	90
160M	11	1470	20.2	15.4	71.5	91.3	91.8	91.4	0.78	0.84	0.86	7.95	2.70	2.95	60	0.1080	125
160L	15	1470	27.3	20.8	97.6	91.9	92.5	92.1	0.78	0.84	0.86	8.30	2.85	3.08	60	0.1090	143
180M	18.5	1470	33.5	25.6	120	91.8	92.6	92.6	0.75	0.82	0.86	8.53	2.79	3.30	62	0.1590	185
180L	22	1470	39.7	30.3	143	92.1	93.0	93.0	0.75	0.82	0.86	9.28	2.71	3.48	62	0.1930	195
200L	30	1480	53.2	40.5	194	92.9	93.6	93.6	0.74	0.82	0.87	8.95	2.80	3.37	64	0.311	250
225S	37	1480	65.0	49.5	239	93.2	94.0	93.9	0.80	0.86	0.87	8.44	2.65	3.27	66	0.612	300
225M	45	1480	79.0	60.2	290	93.5	94.2	94.2	0.80	0.85	0.87	8.56	3.13	3.31	66	0.679	342
250M	55	1480	96.0	73.1	355	93.3	94.4	94.6	0.79	0.85	0.87	8.26	2.51	3.21	68	0.841	391
250M	75	1485	133	101	482	93.8	94.9	95.0	0.76	0.82	0.86	7.52	2.28	2.78	68	1.530	417
280M	90	1485	158	120	579	94.2	94.9	95.2	0.78	0.84	0.86	7.35	2.21	2.64	68	1.770	632
280M	110	1485	186	142	707	93.1	94.8	95.4	0.77	0.85	0.89	7.85	2.30	3.99	70	3.010	682
315M	132	1485	225	171	845	93.6	95.0	95.6	0.79	0.86	0.89	7.95	2.44	3.99	70	3.741	1020
315L	160	1490	270	206	1026	95.0	95.5	95.8	0.83	0.88	0.89	7.44	2.22	3.00	70	4.769	1090
315L	200	1490	337	257	1282	94.5	95.7	96.0	0.83	0.88	0.89	7.05	2.13	3.00	73	5.160	1223
355M	250	1490	421	321	1602	94.3	95.6	96.0	0.84	0.88	0.89	7.80	2.54	2.74	80	8.030	1723
355L	275	1490	465	354	1763	95.1	95.8	96.0	0.86	0.89	0.89	6.83	2.14	2.46	80	8.760	1870
355L	315	1490	537	409	2019	94.3	95.5	96.0	0.82	0.87	0.89	7.19	2.24	2.55	80	9.560	1986

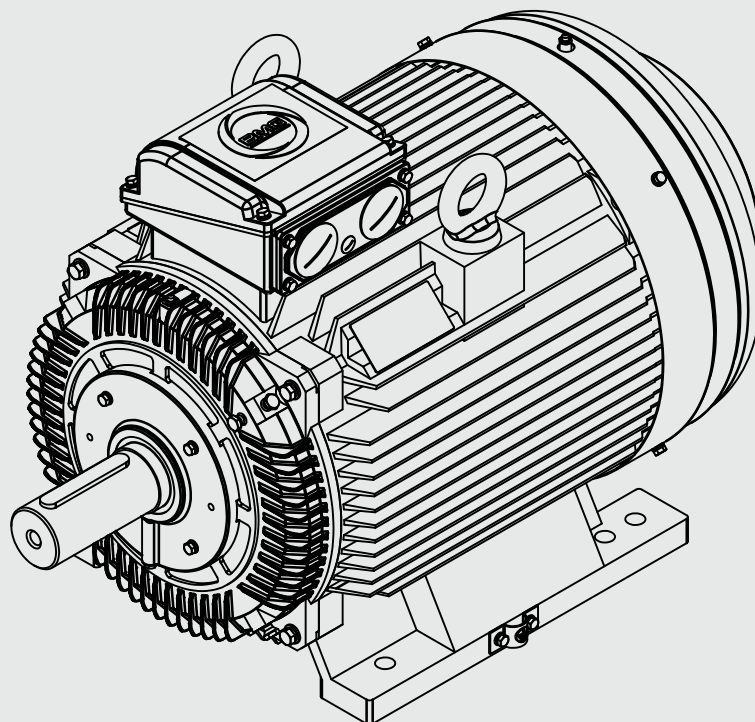
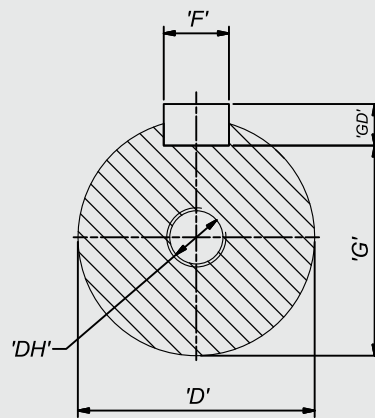
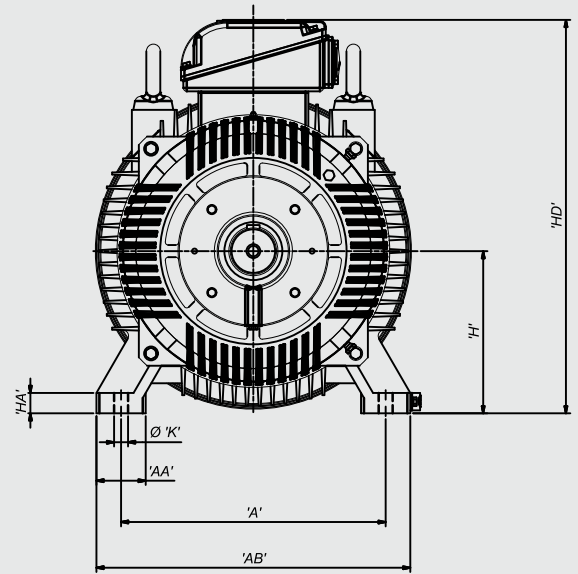
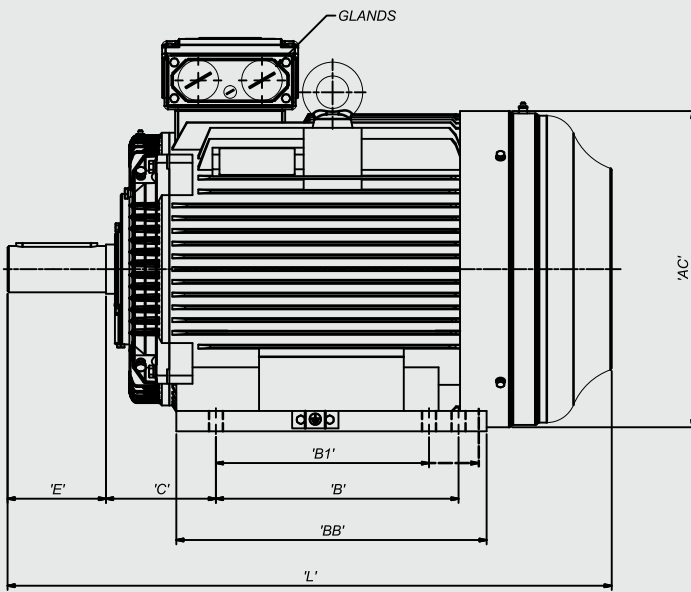

200 085-001 REV: 7

Frame Size	DIMENSIONS FOR IE2 CAST IRON INDUCTION MOTORS														2-POLE		4-POLE		6-POLE		8-POLE											
	A	AA	AB	AC	B	B1	BB	C	ØD	ØDH	E	F	G	GD	H	HA	HD	ØK	L	GLANDS	ØD	ØDH	RM	KG	RM	KG	RM	KG	RM	KG		
80M	125	35	160	165	100	-	135	50	19	M6x16	40	6	15.5	6	80	10	225	10	310	(1x) M25x1.5	17	0.55	17	0.55	17	0.55	17	0.55	17	0.55		
90S	140	36	174	185	100	-	130	56	24	M8x20	50	8	20	90	12	250	10	320	(1x) M25x1.5	1.1	1.1	18	0.75	18	0.75	18	0.75	18	0.75			
90L					125	100	155												345		2.2	2.6	3.4									
100L	160	40	200	205	140	-	179	63	28	M10x25	60	8	24	7	100	14	275	12	388	(1x) M25x1.5	3	3.4										
112M	190	45	235	230	140	-	180	70	28	M10x25	60	8	24	7	112	15	310	12	390	(2x) M32x1.5	4	4.1										
132S					140	-	182												462		5.5	6.0										
132M	216	55	270	270	178	140	220	89	38	M12x30	80	10	33	8	132	18	345	12	500	(2x) M32x1.5	5.5	6.3										
160M	254	65	315	315	210	-	260	108	42	M16x36	110	12	37	8	160	20	415	14	614	(2x) M32x1.5	11	10.9	11	11.5	11	11.5	11	11.5	11	11.5	11	11.5
160L					254	210	304												658		18.5	13.6	15	13.5	11	13.3	11	13.3	11	13.3		
180M	279	70	350	355	247	-	180M	121	48	M16x36	110	14	42.5	9	180	22	450	14	728	(2x) M32x1.5	22	17.2	18.5	17.0	17.0	18.5	17.0	17.0	18.5	17.0	17.0	
180L					279	241	349												780		30	23.3	30	23.5	18.5	21.9	15	23.4	15	23.4		
200L	318	70	388	400	305	-	370	133	55	M20x42	110	16	49	10	200	25	540	19	780	(2x) M50x1.5	37	24.2										
225S 2P	356	75	430	450	286	-	361	149	55	M20x42	110	16	49	10	225	28	590	19	825	(2x) M50x1.5	45	30.2										
225S 4-8P					286		311												820		45	30.2										
225SM 2P	356	75	430	450	311	286	386	149	60	M20x42	140	18	53	11	225	28	590	19	850	(2x) M50x1.5	55	38.2										
225SM 4-8P					311	286	386												850		55	38.2										
250SM 2P	406	80	485	485	349	311	445	168	60	M20x42	140	18	53	11	250	32	625	24	915	(2x) M63x1.5	75	41.0										
250SM 4-8P					349	311	445												968		55	38.5	37	38.0	30	37.5	30	37.5	30	37.5		
280S 2P	457	85	545	550	368	-	485	190	65	M20x42	140	18	58	11	280	35	680	24	998	(2x) M63x1.5	90	54.5										
280S 4-8P					368		419												1020		90	54.5										
280SM 2P	457	85	545	550	419	368	540	190	65	M20x42	140	18	58	11	280	35	680	24	1050	(2x) M63x1.5	110	56.8										
280SM 4-8P					419	368	540												1050		90	60.5	55	54.5	45	56.0	45	56.0	45	56.0		
315SM 2P	508	120	630	625	457	406	680	216	65	M20x46	140	18	58	11	315	45	830	28	1315	(2x) M63x1.5	132	98.0										
315SM 4-8P					457	406	680												1345		160	106.5	110	112.0	90	108.3	110	112.0	90	108.3		
*315ML 2P																			1315		185	119.0										
*315ML 4-8P	508	120	630	625	457	406	680	216	70	M20x46	170	25	81	14	315	45	830	28	1345	(2x) M63x1.5	200	119.0										
*315ML 4-8P					457	406	680												1345		200	119.0										
355ML 2P	610	120	730	710	630	580	750	254	90	M20x56	170	25	81	14	355	52	990	28	1540	(2x) M63x1.5	250	171.0										
355ML 4-8P					630	580	750												1580		315	192.0										
355ML 2P	610	120	730	710	630	580	750	254	90	M20x56	170	25	81	14	355	52	990	28	1540	(2x) M63x1.5	315	192.0										
355ML 4-8P					630	580	750												1580		315	192.0										

Important:
 For M frames, drill S & M Holes in Feet.
 For L frames, Drill M & L Holes in Feet.
 * South African Market Requirement

Component	Colour	RAL	Thickness	Mix (Paint:Thinner)
Motor Housing and End Shield	Black	SHG9005	60-120µm	3 : 1
Fan Cover	Red	3007	40-80µm	8 : 1

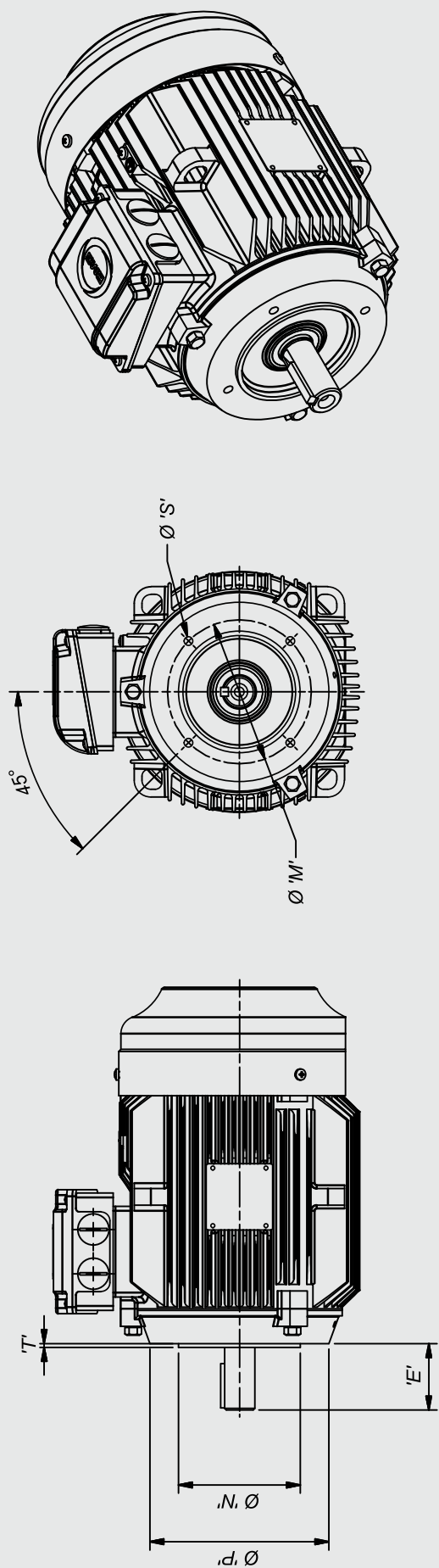

Dimensions for IE2 Cast Iron Induction Motors

FRAME SIZE	2-Pole				4-Pole		6-Pole		8-Pole						
	E	Ø M	Ø N	Ø P	T	Ø S	No. of Holes	kW	Kg	kW	Kg	kW	Kg	kW	Kg
80M	40	100	80	120	3	M6	4	0.75	17	0.55	18	0.37	18	-	-
90S	50	115	95	140	3	M8	4	1.1	18	0.75	19	0.55	20	-	-
								1.5	23	1.1	23	0.75	24	0.37	22
90L								2.2	26	1.5	29	1.1	26	0.55	24
100L	60	130	110	160	3.5	M8	4	3	34	-	-	1.5	34	-	-
112M	60	130	110	160	3.5	M8	4	-	-	2.2	35	-	-	0.75	31
								-	-	3	39	-	-	1.1	32
132S	80	165	130	200	4	M10	4	4	41	4	45	2.2	40	1.5	38
								-	-	5.5	62	3	57	2.2	55
132M	80	165	130	200	4	M10	4	5.5	60	-	-	-	-	-	-
								7.5	63	-	-	-	-	-	-
								-	-	7.5	74	-	-	3	71
								-	-	-	-	4	73	-	-
								-	-	-	-	5.5	77	-	-

Component	Colour	RAL	Thickness	Mix (Paint:Thinner)
Motor Housing and End Shield	Black	SHG9005	60-120 µm	3 : 1
Fan Cover	Red	3001	40-80 µm	8 : 1

200 085-003 REV: 5

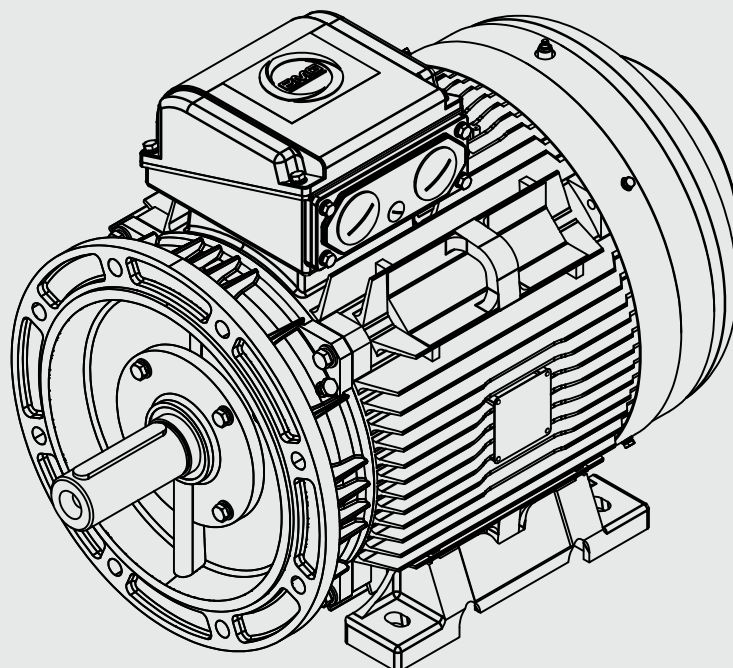
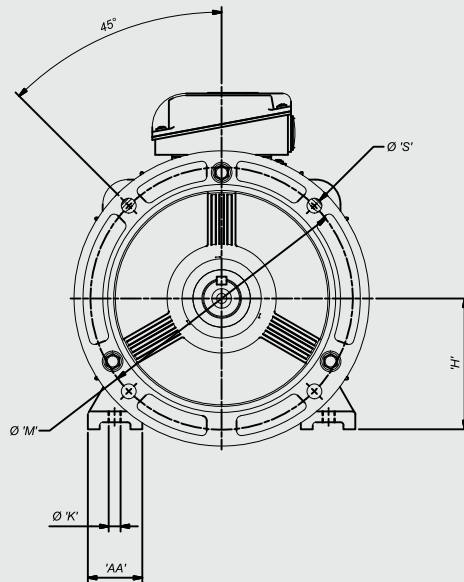
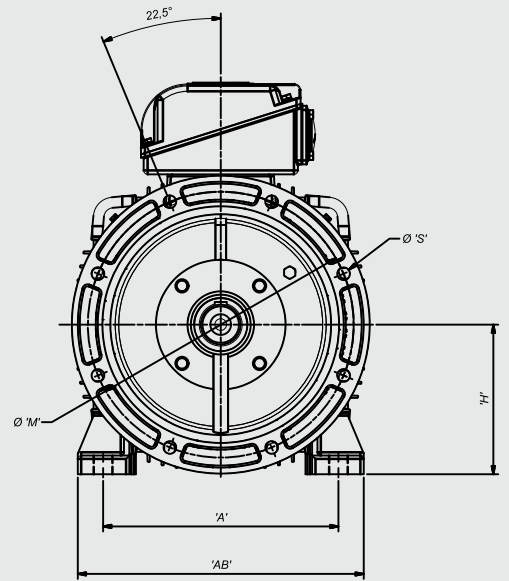
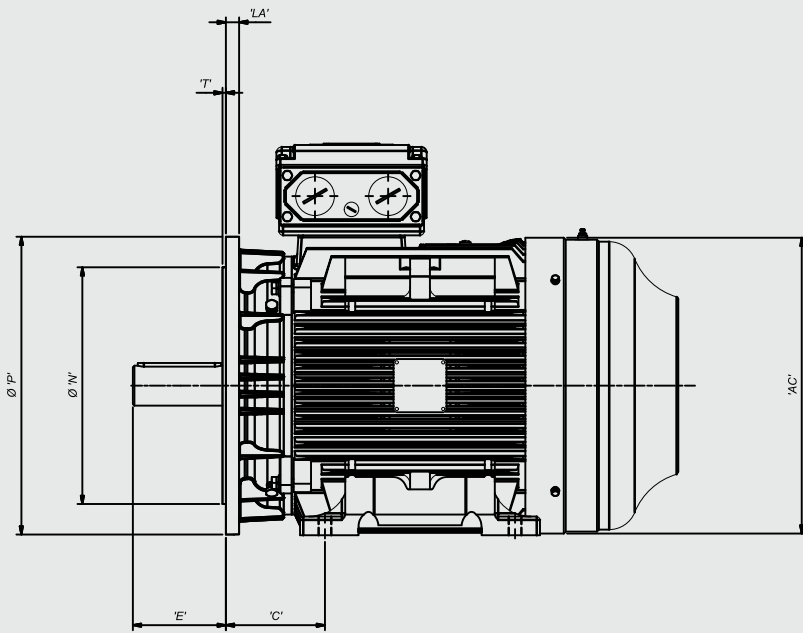

Frame Size	Dimensions for IE2 Cast Iron Induction Motors														2-Pole		4-Pole		6-Pole		8-Pole			
	A	AA	AB	AC	C	E	H	ØK	LA	ØM	ØN	ØP	T	ØS	No. of Holes	KW	Kg	KW	Kg	KW	Kg	KW	Kg	
80M	125	35	160	165	50	40	80	10	12	165	130	200	3.5	12	4	0.75	19	0.55	20	0.37	20	-	-	
90S	140	36	174	185	56	50	90	10	10	165	130	200	3.5	12	4	1.1	20	0.75	21	0.55	22	-	-	
90L	140	36	174	185	56	50	90	10	10	165	130	200	3.5	12	4	1.5	25	1.1	25	0.75	26	0.37	22	
100L	160	40	200	205	63	60	100	12	14	215	180	250	4	15	4	2.2	28	1.5	31	1.1	28	0.55	24	
112M	190	45	235	230	70	60	112	12	14	215	180	250	4	15	4	3	37	2.2	38	1.5	37	-	-	
132S	216	55	270	270	89	80	132	12	14	265	230	300	4	15	4	-	-	3	42	1.1	32	0.75	31	
132M	216	55	270	270	89	80	132	12	14	265	230	300	4	15	4	4	44	4	48	2.2	43	1.5	38	
160M	254	65	315	315	108	110	160	15	15	300	250	350	5	19	4	-	-	5.5	66	-	-	-	-	-
160L	254	65	315	315	108	110	160	15	15	300	250	350	5	19	4	15	127	-	127	7.5	118	4	98	
180M	279	70	350	355	121	110	180	15	15	300	250	350	5	19	4	18.5	144	15	143	11	141	7.5	131	
180L	279	70	350	355	121	110	180	15	15	300	250	350	5	19	4	22	178	18.5	177	-	-	-	-	
200L	318	70	388	400	133	110	200	19	17	350	300	400	5	19	4	30	233	30	246	18.5	230	15	234	
225S 2P	356	75	430	450	149	110	225	19	20	400	350	450	5	19	8	37	252	-	-	22	239	-	-	
225S 4-8P	356	75	430	450	149	110	225	19	20	400	350	450	5	19	8	-	-	37	304	-	-	-	18.5	276
225SM 2P	356	75	430	450	149	110	225	19	20	400	350	450	5	19	8	45	316	-	45	340	30	310	22	298
225SM 4-8P	356	75	430	450	149	110	225	19	20	400	350	450	5	19	8	55	406	-	45	340	30	310	22	298
250SM 2P	406	80	485	485	168	140	250	24	22	500	450	550	5	19	8	75	434	-	55	406	37	400	30	375
250SM 4-8P	406	80	485	485	168	140	250	24	22	500	450	550	5	19	8	-	-	75	485	45	485	37	480	
280S 2P	457	85	545	550	190	140	280	24	22	500	450	550	5	19	8	-	-	-	-	-	-	-	-	-
280S 4-8P	457	85	545	550	190	170	280	24	22	500	450	550	5	19	8	90	559	-	-	-	-	-	-	-
280SM 2P	457	85	545	550	190	140	280	24	22	500	450	550	5	19	8	110	582	-	620	55	560	45	560	
280SM 4-8P	457	85	545	550	190	170	280	24	22	500	450	550	5	19	8	-	-	90	620	55	560	45	560	
315SM 2P	508	120	630	625	216	140	315	28	22	600	550	660	6	24	8	132	1007	-	110	665	75	881	55	915
315SM 4-8P	508	120	630	625	216	170	315	28	22	600	550	660	6	24	8	180	1117	-	-	-	-	-	-	-
*315ML 2P	508	120	630	625	216	140	315	28	22	600	550	660	6	24	8	-	-	132	1044	90	975	75	981	
*315ML 4-8P	508	120	630	625	216	170	315	28	22	600	550	660	6	24	8	-	-	160	1112	110	1147	90	1083	
*315ML 2P	508	120	630	625	216	140	315	28	22	600	550	660	6	24	8	185	1217	-	-	-	-	-	-	-
*315ML 4-8P	508	120	630	625	216	170	315	28	22	600	550	660	6	24	8	-	-	185	1227	-	-	-	-	-
355ML 2P	610	120	730	710	254	210	355	28	25	740	680	800	6	24	8	200	1217	-	200	1227	-	-	-	-
355ML 4-8P	610	120	730	710	254	210	355	28	25	740	680	800	6	24	8	250	1755	-	250	1785	-	-	-	-
355ML 2P	610	120	730	710	254	170	355	28	25	740	680	800	6	24	8	-	-	-	-	-	-	-	-	-
355ML 4-8P	610	120	730	710	254	210	355	28	25	740	680	800	6	24	8	315	1965	-	-	-	-	-	-	-
355ML 2P	610	120	730	710	254	170	355	28	25	740	680	800	6	24	8	-	-	-	-	-	-	-	-	-
355ML 4-8P	610	120	730	710	254	210	355	28	25	740	680	800	6	24	8	280	1915	-	280	1915	-	-	200	2060
355ML 2P	610	120	730	710	254	170	355	28	25	740	680	800	6	24	8	-	-	-	-	-	-	-	-	-
355ML 4-8P	610	120	730	710	254	210	355	28	25	740	680	800	6	24	8	315	1965	-	315	2020	-	-	200	2060

Component	Colour	RAL	Thickness	Mix (Paint:Thinner)
Motor Housing and End Shield	Black	SHG9005	60-120µm	3 : 1
Fan Cover	Red	3001	40-80µm	8 : 1

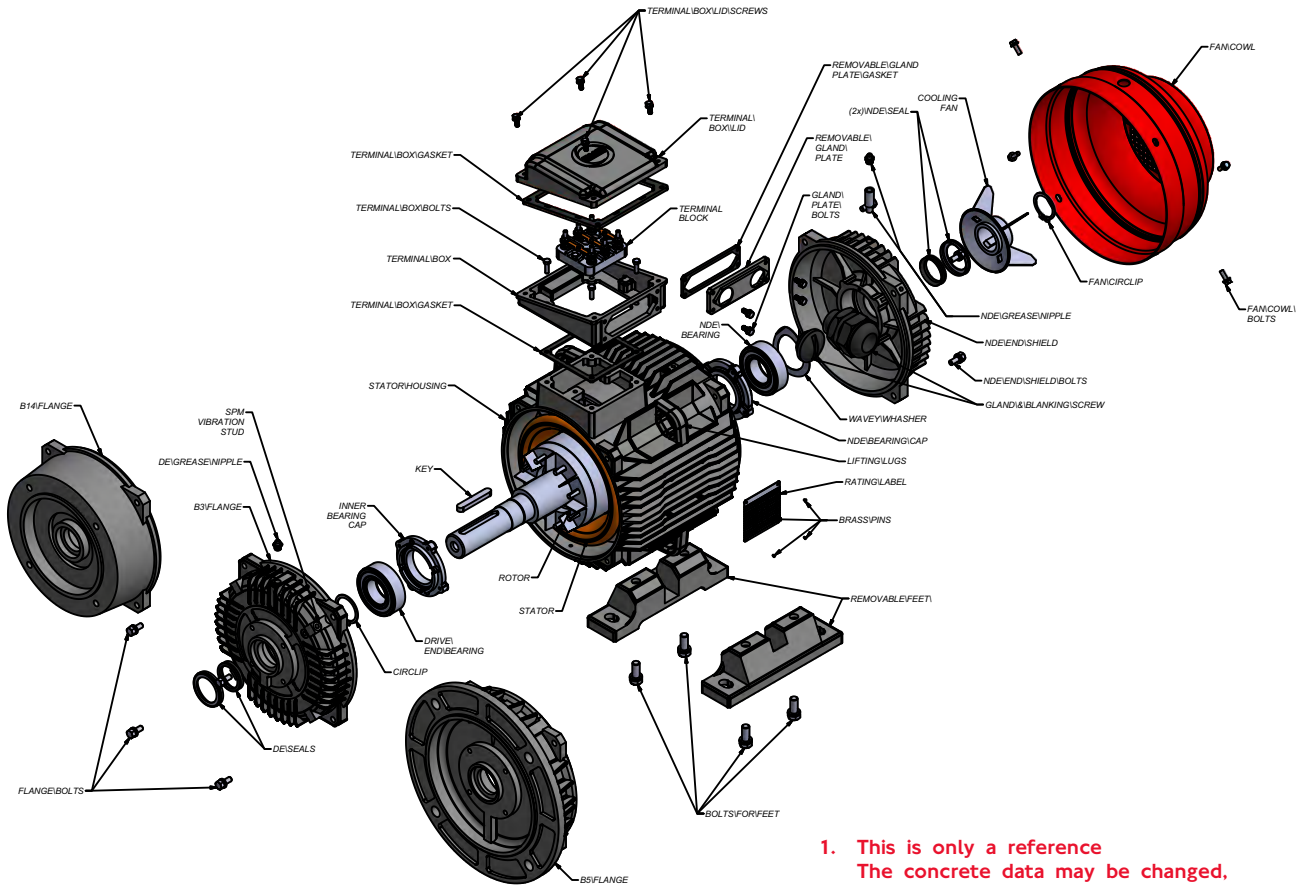

1. This is only a reference
The concrete data may be changed,
please contact us before ordering.

Electrical Formulae

$$1) \text{ Active kW} = \frac{\text{kVA} \times \text{PF}}{\text{or}} \frac{\text{Line Amps} \times \text{Line Volts} \times 1.732 \times \text{PF}}{1000}$$

$$2) \text{ Rated kW} = \frac{\text{kVA} \times \text{PF} \times \text{eff}}{\text{or}} \frac{\text{Line Amps} \times \text{Line Volts} \times 1.732 \times \text{PF} \times \text{eff}}{1000} \text{ or HP} \times 0.746$$

$$3) \text{ Rated HP} = \frac{\text{Active kW} \times \text{eff}}{0.746} \text{ or } \frac{\text{Line Amps} \times \text{Line Volts} \times 1.732 \times \text{pf} \times \text{eff}}{746}$$

$$4) \text{ Apparent kVA} = \frac{\text{Rated kW}}{\text{eff} \times \text{PF}} \text{ or } \frac{\text{HP} \times 0.746}{\text{eff} \times \text{PF}} \text{ or } \frac{\text{Line Amps} \times \text{Line Volts} \times 1.732}{1000}$$

$$5) \text{ Line Amps} = \frac{\text{Rated kW} \times 1000}{\text{Line Volts} \times 1.732 \times \text{PF} \times \text{eff}} \text{ or } \frac{\text{Rated HP} \times 746}{\text{Line Volts} \times 1.732 \times \text{PF} \times \text{eff}}$$

$$6) \text{ Rated Torque (Nm)} = \frac{9.55 \times \text{Rated kW} \times 1000}{\text{Rated Speed of Motor (r/min)}}$$

$$7) \text{ Rated kW} = \frac{\text{Rated Torque (Nm)} \times \text{Rated Speed of Motor (r/min)}}{9.55 \times 1000}$$

$$8) \text{ Rated Slip \%} = \frac{\text{Synchronous Speed Minus Rated Speed}}{\text{Synchronous Speed}} \times 100$$

$$9) \text{ Starting Time (s)} = \frac{\text{Total Inertia kg m}^2 \text{ (WR}^2\text{)} \times \text{Working Speed (r/min)}}{9.55 \times \text{Mean Acceleration Torque (Nm)}}$$

$$10) \text{ Synch. Speed (r/min)} = \frac{\text{Frequency (Hz)} \times 60}{\text{Number of Pairs of Poles}}$$

PF : Power Factor

eff : Efficiency

Rated kW : Mechanical Power Delivered by Motor Shaft

Active kW : Input Power

Bmg Synergy IE3

New Efficiency Regulation

The IEC has published the new standard related to energy-efficiency: 60034-30. This standard globally harmonizes energy-efficiency classes in general-purpose, line-fed, three-phase, single speed squirrel cage, induction motors in the range 1-500hp (0.75-375kw). Four efficiency classes are proposed, namely:

- Standard Efficiency (IE1)
- High Efficiency (IE2) Equivalent to EPACT
- Premium Efficiency (IE3) Equivalent to NEMA Premium
- Super Premium Efficiency (IE4).

IE1, IE2 and IE3 classes were normative. The IE4 class was intended to be informative, since no sufficient market and technological information is available to allow IE4 standardization-IEC60034-31.

The standard also defines that IEC 60034-2-1 must be used with regards to testing methods. The methods defined in this standard are recognised as being of lower uncertainty. Manufacturers must state in their documentation which method they use to determine the stray load losses, because they are not comparable if different methods are used.



For Induction Motors (IE1 to IE4)

IEC 60034-30 and CEMEP/EU Efficiency Levels (4-pole) for 60 & 50 Hz.

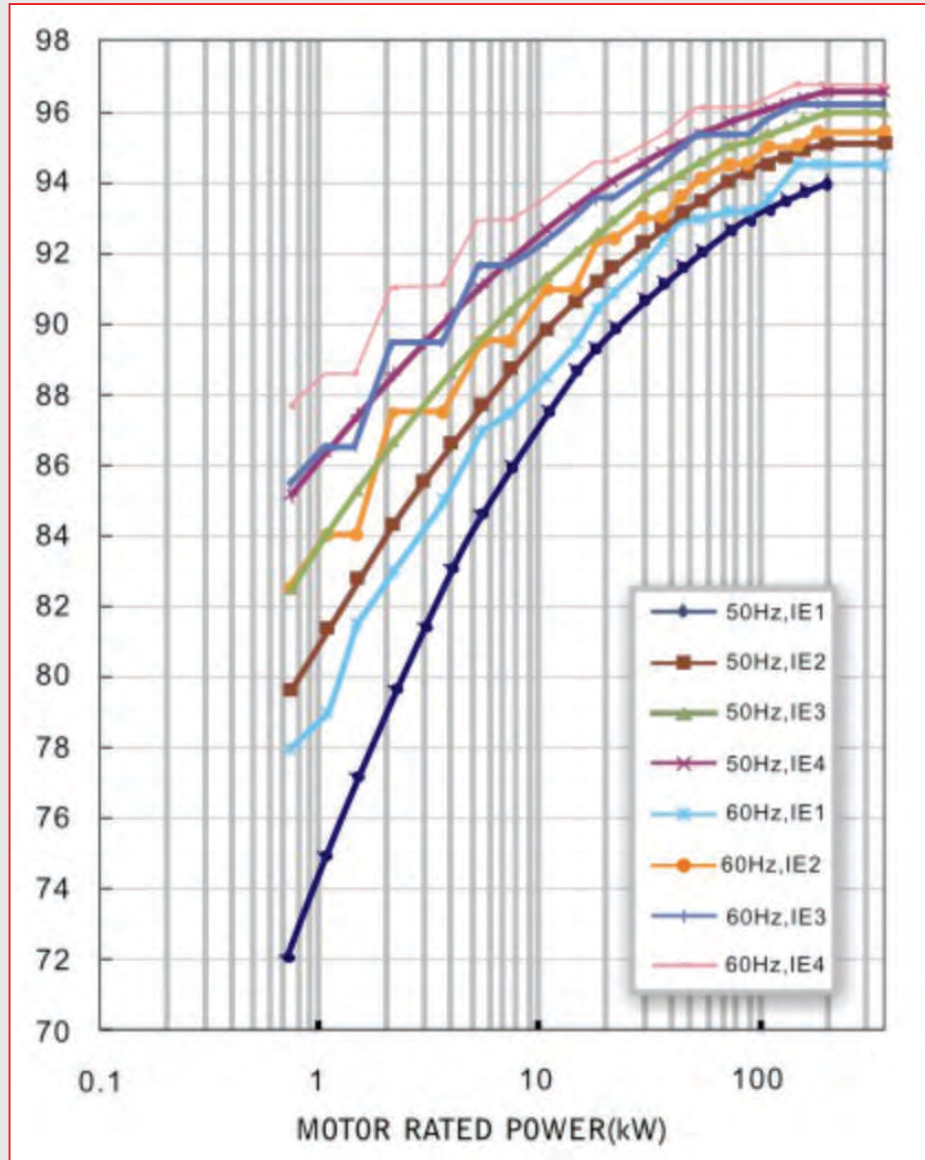

The EuP-Directive 2005/32/EC establishes the Ecodesign requirements for electric-motors and defines High Efficiency (IE2) as minimum efficiency levels as of the 16th June 2011.

The EuP-Directiv 2005/32/EC also establish that Premium Efficiency (IE3) or IE2 & VFD will be required from 0.75kW up to 375kW as of the 1st January 2015. And that the complete kW range 0.75kW up to 375kW in IE3 (or IE2 + VFD) will be required as of the 1st January 2017.

WE (Cast Iron IE2), WEA (Aluminium IE2), SWE (Cast Iron IE3) and SNA (Cast Iron NEMA Super Efficiency) series, IE4 Cast Iron Super Premium efficiency motors are solutions to the new regulation.

Copper Rotor Motor

Saving Energy Loss of up to 40% than the IE2

The IE4 energy-efficiency class is not limited to three-phase cage-induction motors as classes IE1, IE2 and IE3 of IEC 60034-30. IE4 is intended to be used with all types of electrical motors, particularly with converter-fed machines (both cage-induction and permanent-magnet synchronous-motors).

In 60034-30-2, a super-premium (New IE4 Class) must have at least a 15% loss reduction in relation to IE3. With this situation, we are presenting IE4 Copper rotor motor line. The die cast Copper rotor is well adopted to replace the traditional Aluminium rotor, changing the design of the rotor and motor to apply copper more effectively. Copper in the rotor reduced the resistive losses in the motor on the order of 40% and has the potential to reduce the overall losses by 10-20%, compared with conventional Aluminium rotor motors. Those motors with Copper rotors can be made smaller and lighter and can operate at lower temperatures to decrease maintenance requirements. Copper rotor motors typically have a higher locked-rotor current and a lower pull-up torque compared to Aluminium rotor motors. By appropriate design measurements to meet the starting performance characteristics as defined in 60034-31:2009.

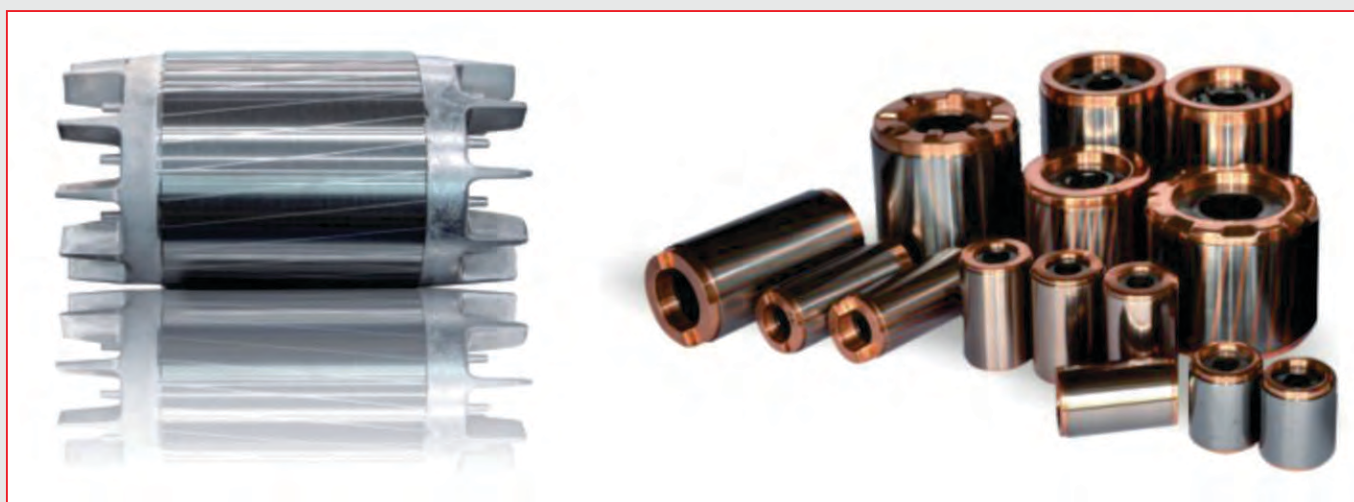

IE4 motors meet all the energy efficient requirements defined in draft IEC60034-30-2 and IEC60034-31.

Frame Size	132S-355M/L	Poles	2,4 & 6 Poles
Output Range	3kW-315kW	Voltage	400V, 50Hz



Why Choose Synergy High Efficiency Motors?

The synergy series motors are BMG's answer to the global demand for energy-saving. It also encompasses many performance advantages in terms of noise and vibration levels, higher reliability, easier maintenance, flexibility and a lower cost of operation.

Complete New Design

Compared to many other manufacturers, Synergy made a complete new design for IE2 and IE3 motors instead of modifying the standard motors by simply enlarging the frame size or lengthening the lamination.



Strictly Tested According to IEC 60034-2-1 Testing Methods

Synergy products incorporate advanced technologies and manufacturing processes and are supported by rigorous testing, according to international standards.

Synergy energy-saving motors are available in three versions, exceeding the minimum levels established by the IEC 60034-30. Synergy is using the indirect method defined in IEC 60034-2-1 with stray load losses being determined from measurement.





Good Interchangeability

The main reason for the postponed implementation dates for the IE3 version is likely difficulties some manufacturers may face to fit IE3 efficiency levels in the same frame size of IE2 and IE1 versions.

The Synergy Energy saving motor is available in the three IEC 60034-30 efficiency levels respecting the kW rating per frame defined in EN 50347, providing the same frame size as the Premium Efficiency and High Efficiency motors. This means that you can replace an IE1 (or previously EFF2) motor with our IE2 and IE3 motor with total peace of mind.



Perfect Insulation System

Synergy always use the best insulation materials such as high grade Copper wire, Slot liners, Slot separators, Phase separators, Wedges, Banding tapes, Impregnating media, Tapes and Sleeving.

In addition to the aging test, other tests such as melting temperature, tensile strength, resistance to heat shock and cut through resistance are also performed, to ensure the insulation system can withstand known operating conditions.



The use of VFD (Variable Frequency Drive) is recognised to be one of the major driving forces for energy efficiency, because it can adjust motor output to best suit the load requirements. However, voltage spikes from the PWM waveform can have harmful effects on the motor winding, leading to premature failure of the insulation system. This will get worse as the switching frequency is increased.

For VFD applications, Synergy motors are fitted with class H Copper wire (200°C) enhanced insulated bearings or insulated endshield, which provides a good solution for new technology application in all industry. For frequency varying between 25-75 Hz, there is no need to install a forced ventilator in Synergy motors.



Compact Design

The IE2 platform, offering high efficiency and low lifetime costs, will be the basis for the further Synergy developments. In addition to new permanent magnet motors and Flame-proof motors the design of compact motors with optimized materials of construction offers a reduced frame size per output.

The methods used by Synergy, to achieve higher efficiency are very different from the normal approach of moving to a larger frame size. We developed high efficiency motors with higher output power in the same frame size, which has the benefits of a smaller size, lighter weight, and smarter appearance.



Maximum Flexibility

Both integrated and removable feet are available, which provide flexibility during installation. Solid motor feet provide a more resistant structure against vibration, while removable feet can be placed on different positions of the motor frame.

The new design allows the terminal box to be mounted top, right or left and be rotated 360° without disassembling the complete motor, thus reducing modification time and reducing stock.

In order to satisfy some special customer needs, Synergy have also designed Aluminium housing motor with a Cast Iron endshield for frame sizes up to 180, which could dramatically enhance the solidity of the motor and reduce the noise.



State-of-the-art Engineering And Processing Facility

At Synergy, technology is a core competitive advantage. Manufacturing is a fundamental part of the process. Synergy has modern facilities and experienced engineers, which guarantee the capability of processing the special shafts, endshields and housing. In addition, we are experienced in manufacturing high temperature and variable frequency motors. Synergy has laboratories for conducting in house tests and produces machines with variable power capacity and increasing intelligence.



Lower Total Operational Costs for Users

Energy costs correspond to approximately 90% of the total operational costs throughout the motor lifetime, the other 10% being acquisition, installation and maintenance cost. Synergy motors can operate most of its lifetime consuming the minimum possible energy with high levels of productivity, operating continuously without unplanned stops with top performance, thus guaranteeing energy savings and reduced payback time.

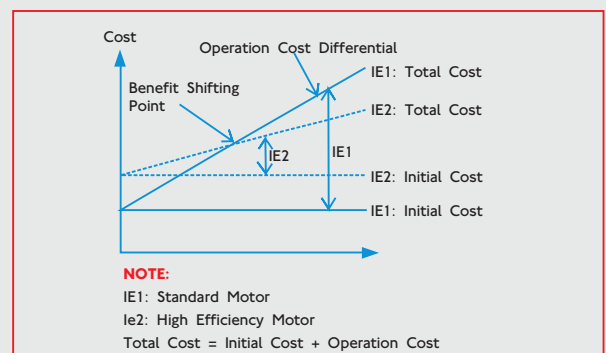

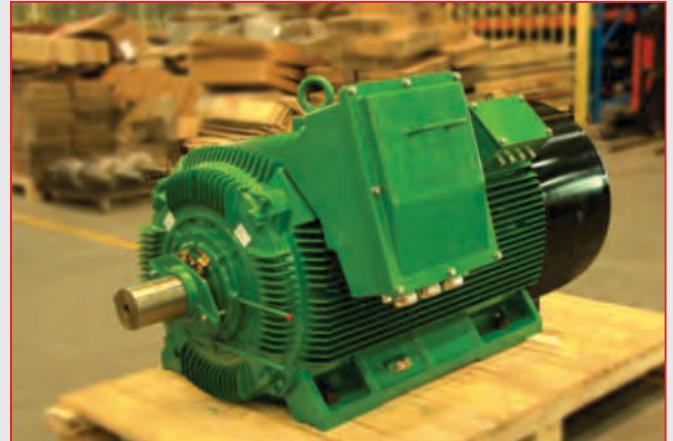

Complete Range of High Efficiency Motor

BMG in conjunction with Synergy developed high efficiency motors and now has a full range of IE2 motors available from frame size 80 to 450 with power from 0.37 kW to 900 kW. We also have completed IE3 models and made in mass production.

Reduced Operating Temperature

Cooler running temperatures are preferable. To reduce the temperature by just 10°-15°C can double the lifetime of a motor. The normal frame surface temperature in a high reliability motor running at full load can be as low as 60-80°C.

Redesigned to provide improved air flow through all motor frames keeping low operational temperatures and assuring reliability and extend lifetime. The aerodynamic concept of the fan cover increases effective airflow, thus minimizing losses due to the recirculation of air between the fan and fan cover.

The impeller was designed to provide a tough structure and reduce noise level. The motor terminal box and eyebolts was repositioned to allow better airflow.

This optimised cooling system also contributes to:

- Cooler bearing temperature will extend relubrication intervals and provide a longer bearing lifetime.
- Lower noise level will fulfill the most demanding Health & Safety regulations.
- Lower Overall Operational Temperature will result in a more efficient material use.

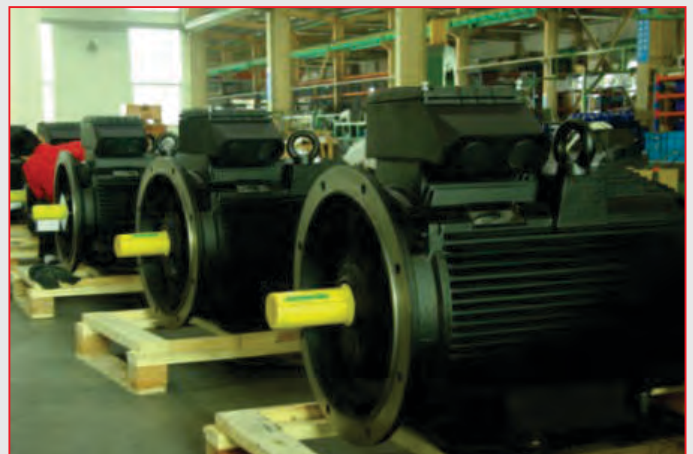

SYNERGY HIGH EFFICIENCY MOTORS

Certification Guaranteed

Due to sufficient quality control systems and environment management, the company has been certified with ISO9001:2008 & ISO14001:2004. To date, Synergy motors have been approved by TUV, CE, SABS, CCS Australian MEPS and etc.

Our high efficiency motors have been certified by Anglo-American, Shanghai testing and the inspection Institute for Electrical Equipment and the National Quality Supervision and Inspection Center for Flame-proof Electric Products.

Besides, Synergy is the first enterprise to get a third-party certificate for high efficiency motors.



BEE4

EMPOWERING SUPPLIER

ISO 9001	Certified
ISO 14001	Certified
ISO 45001	Certified



RoHS



Quality Focused Philosophy

Synergy insists on producing high quality products and committing to ultimate customer satisfaction.

Synergy's expertise in the field of electrical motors and their many years of experience, innovative production and the total quality control standard during construction and production, ensures a maximum quality on all products.



Genuine High Efficiency

IE2 or EFF1 is easy to achieve by simply increasing the amount of active material in the motor i.e. more Copper in the slots and smaller air gaps in the design. The challenge is that the IEC60034-2 sets tolerances for efficiency.

Synergy motors are all for efficiency at the uppermost of the tolerance band and never allows lower tolerance levels. Synergy Standard Efficiency, High Efficiency and Premium Efficiency designs exceed IE1, IE2 and IE3 levels, defined by IEC 60034-30.

Getting the right balance between efficiency, temperature rise and noise will go a long way to lower life cycle costs, running costs and increasing the overall reliability of an electric motor.

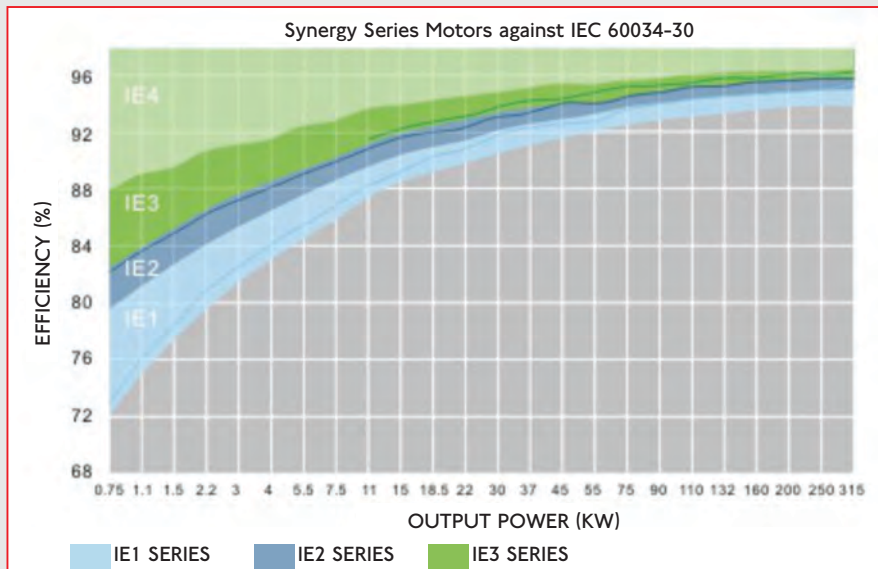

Reliability Guaranteed

The cost of a failed motor in production can be immense. Experience shows that there are many motors which achieve IE2 status, at the cost of significant drawbacks. Increased running temperatures and excessive noise are common examples.

Reliability could be defined as the sum of efficiency plus temperature rise. These elements directly affect each other and finally the quality and reliability of a motor.

BRINGING THE WORLD'S BEST BRANDS TO YOU

In the bid to procure cutting-edge components at competitive prices, BMG is able to capitalise on long-standing relationships with leading manufacturers dedicated to excellence in design and production.

Products are imported from around the globe and brought to BMG's strategically located distribution facilities and regional service centres via the main distribution hub in Johannesburg - BMG World. A world-class facility boasting 308 000m³ of fully stocked warehouse space, an accredited training facility and unlimited engineering capabilities.

Preferred Brands:



Our Extensive Coverage Throughout Africa

98
BRANCHES

Products and services are distributed via BMG's extensive distribution network. It's through the sheer size and reach of our infrastructure, that BMG can be found wherever industry has established itself; delivering the correct components at the right time, to the far-flung coalface of our customers' operations.

- Over 300 000 product line items
- Around 4 500 transfers per day out of BMG World in Johannesburg
- Over 1 000 tons of imported stock landing per month
- 98 strategically situated branches throughout Africa
- Vendor Managed Inventory sites (dedicated on-site stockholding)
- International exports
- Locally empowered distribution chains



24 HR TOLL-FREE EMERGENCY
BRANCH HELPLINE:

0800 022 224

WEBSITE:

www.bmgworld.net



An Invicta Holdings Group Company

BEARINGS • SEALS • POWER TRANSMISSION • DRIVES & MOTORS
MATERIALS HANDLING • FASTENERS & TOOLS • HYDRAULICS
PNEUMATICS • FILTRATION • LUBRICATION • VALVES
TECHNICAL RESOURCES • FIELD SERVICES

