



DINAMIC OIL
Sugar Technologies

B-BBEE 2
EMPOWERING SUPPLIER

ISO 9001	Certified
ISO 14001	Certified
ISO 45001	Certified

Established in 1974 as a single bearing shop in Durban, South Africa; BMG's aggressive growth strategy has included acquisitions, supplemented by a steady organic growth discipline. BMG attracts best-of-breed talent resulting in technical expertise that differentiates BMG in the industry. Staff are truly part of the BMG family and its success.

BMG boasts an accredited in-house technical and commercial training academy which fosters a culture of staff development and career advancement; it's all about sustainability.

The net result, is a company that reliably supplies and supports 70 000 customers in 15 countries with the widest range of industrial engineered products and expert services in Africa via 98 branches.

BMG is positioned to deliver bespoke 360 degree solutions to its customers, and subsequently return on investment to its investors and shareholders. BMG plays a pivotal role in supporting the productivity and production targets of all Industrial, Manufacturing, Mining and Agricultural sectors of the economies in the countries it serves. With an enviable reputation as Africa's largest distributor, manufacturer and service provider of the highest quality engineering consumables and components; including:

- Bearings & Seals
- Power Transmission Components
- Drives, Motors and Controllers
- Hydraulics, Pneumatics and Filtration
- Heavy and Light Duty Materials Handling
- Valves and Lubrication
- Fasteners, Gaskets and Tools

BMG is a level 2 BEE contributor with ISO 9001 Quality Assurance certification. Health and safety of its employees and customers is a paramount focus and the company adheres to ISO 45001. BMG is also committed to environmental care and sustainability and strictly follows the ISO 14001 charter.

As a key contributor to the Invicta Holdings stable, BMG has played a major part in Invicta's unique achievement of being rated in South Africa's Top 100 Companies for 21 consecutive years.



TABLE OF CONTENTS

INDEX

Advanced Planetary Know-how at your disposal	2
About Dinamic Oil	3
Single and Multiple Drive Mill Solutions	4
Sugar Mill Trains	5
Sugar Mill Diffusers	6
Products Range	7



Advanced Planetary Know-how at your disposal

Since 1970 Dinamic Oil has been a leading global manufacturer of Hoisting Winches. These winches are complemented by a range of Planetary Gearboxes with output torques from 1,000 Nm to 4,000,000 Nm. Thanks to continuous research and development, Dinamic Oil is supplying innovative and reliable products to the most demanding industries.

This document shows many examples where Dinamic Oil has provided successful solutions in a variety of globally recognized Sugar Cane Applications.

About Dinamic Oil

For more than 10 years Dinamic Oil has been providing innovative custom solutions to the Sugar Industry.

Dinamic Oil Planetary Gearboxes and Winches are successfully driving Cane Carriers, Feeder Tables, Pushers, Rack Carriers, Inter Rack and Bagasse Elevators, Bagasse Conveyors, GRPF, RBC (Return Bagasse Carrier), Wagon Tilters, and many other Sugar Cane Applications worldwide.



Single and Multiple Drive Mill Solutions

Dinamic Oil proposes innovative custom solutions for Sugar Cane Mills of any size and configuration.

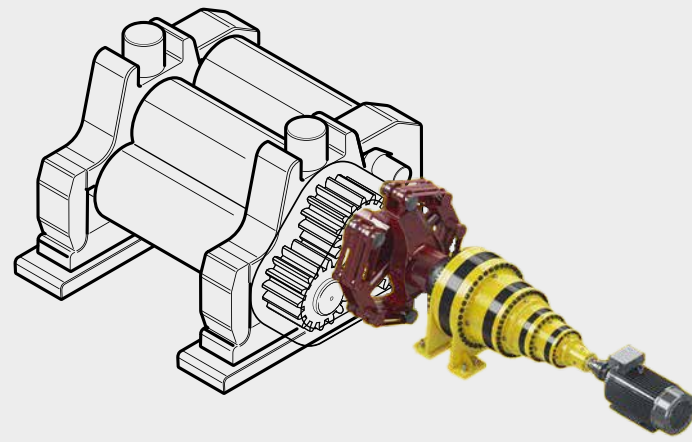

Model	T ₂ nom	T ₂ max
GB	kNm	kNm
85000	900	1500
110000	1150	2350
130000	1370	2950
150000	1850	4000
205000	2350	4100
235000	2650	4500
310000	3200	5350
410000	4600	7100

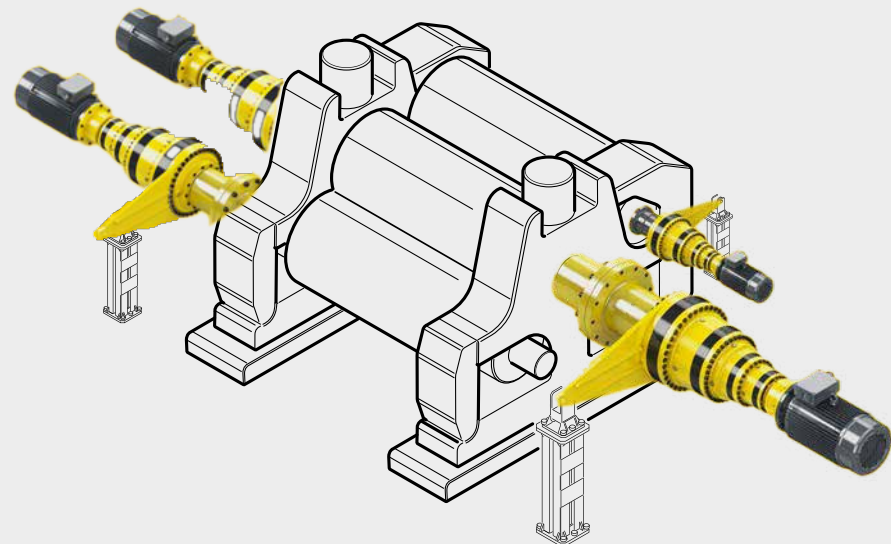

Products Range

Dinamic Oil's great variety of sizes, configurations and accessories make our range suitable for all the Sugar Mill Applications.



Sugar Mill Trains

As Main or Assist Drives, Dinamic Oil Gearboxes meet the demand of high torque and efficiency related to the cane grinding process.

Sugar Mill Diffusers

Dinamic Oil Planetary Gearboxes are the ideal Diffuser Drive solution, where the challenge is the reliability at high torque and low speed requirements.

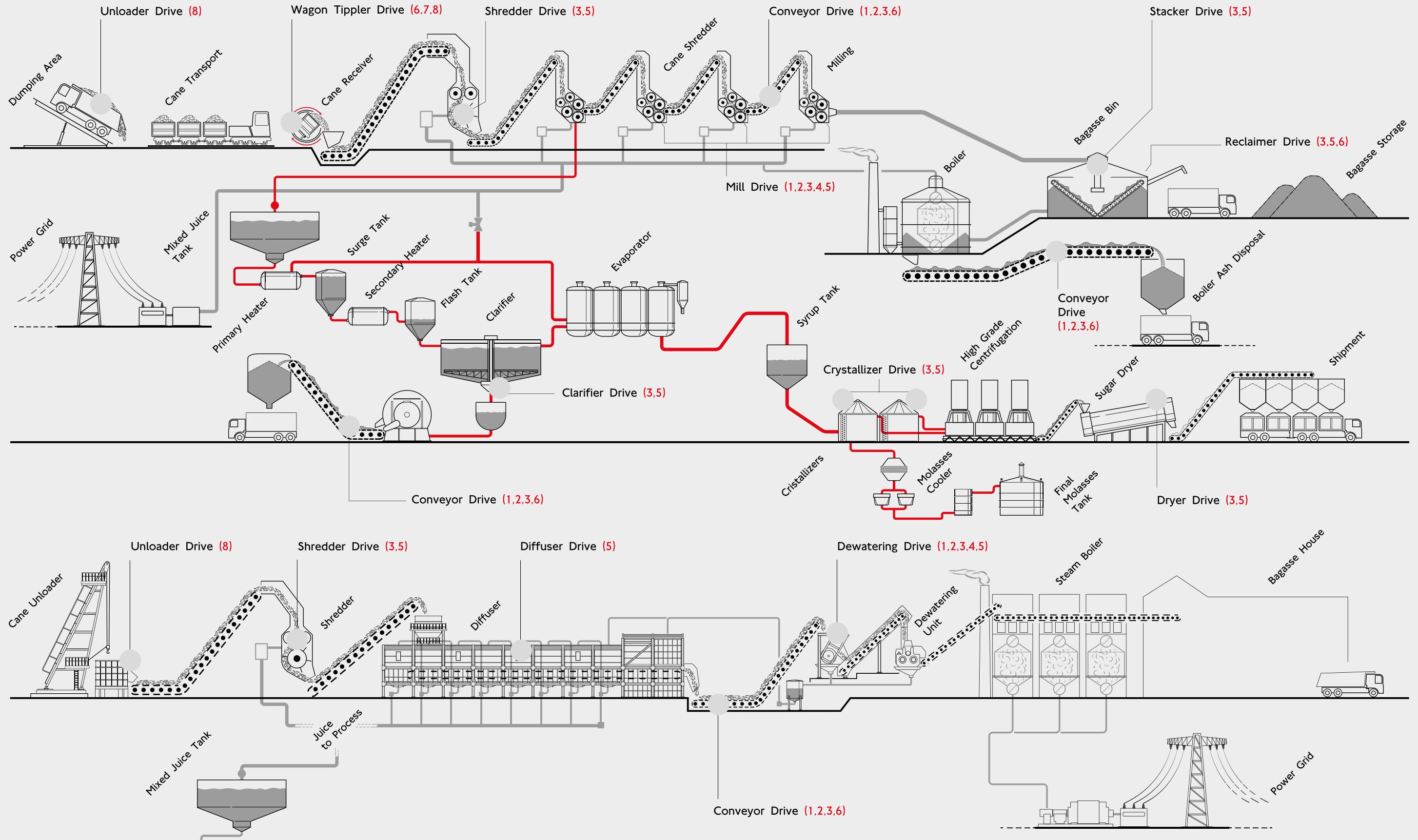

In the bid to procure cutting-edge components at competitive prices, BMG is able to capitalise on long-standing relationships with leading manufacturers dedicated to excellence in design and production.

Products are imported from around the globe and brought to BMG's strategically located distribution facilities and regional service centres via the main distribution hub in Johannesburg - BMG World. A world-class facility boasting 308 000m³ of fully stocked warehouse space, an accredited training facility and unlimited engineering capabilities.

Preferred Brands:



Our Extensive Coverage Throughout Africa

98
BRANCHES

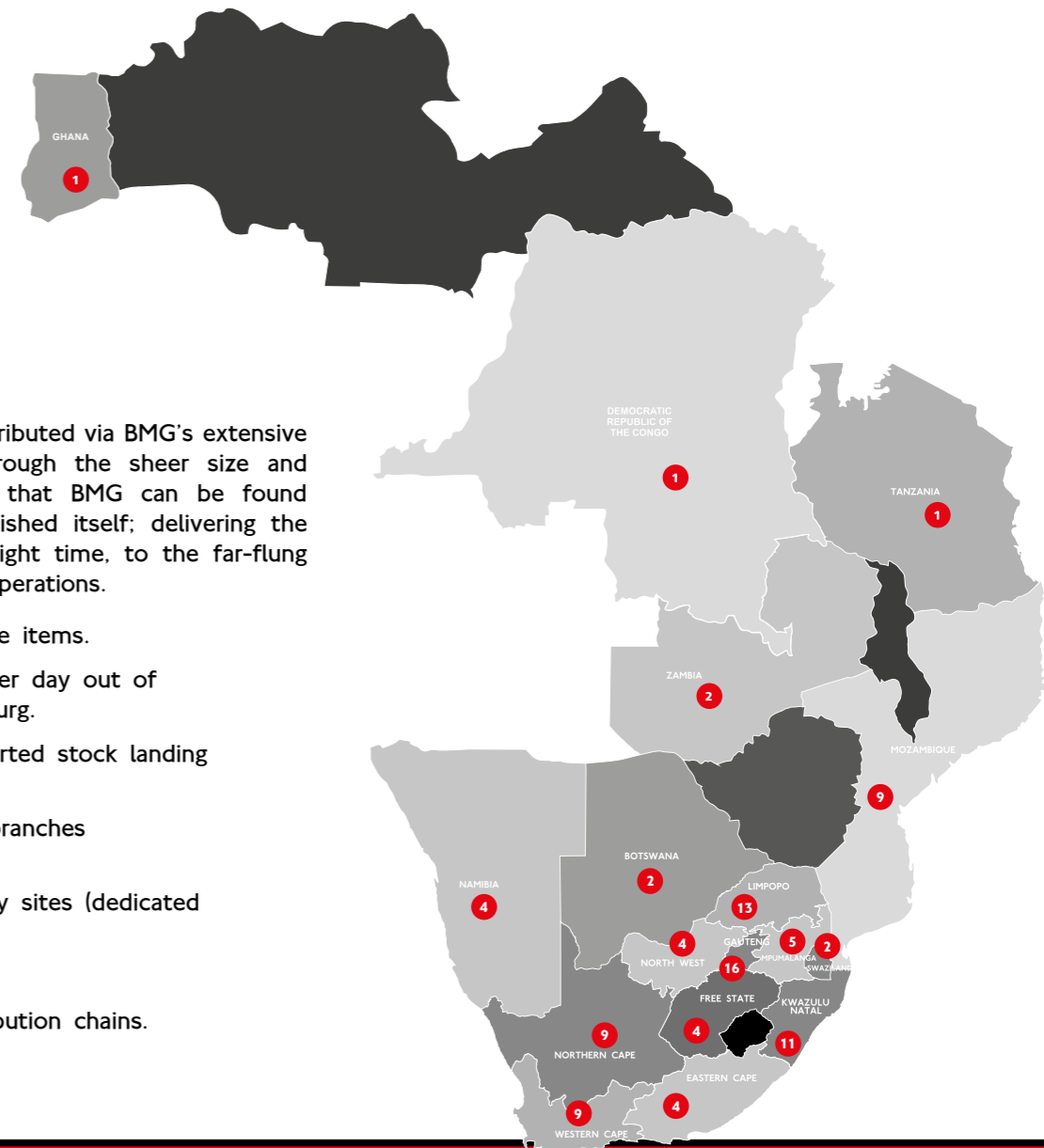

Products and services are distributed via BMG's extensive distribution network. It's through the sheer size and reach of our infrastructure, that BMG can be found wherever industry has established itself; delivering the correct components at the right time, to the far-flung coalface of our customers' operations.

- Over 300 000 product line items.
- Around 4 500 transfers per day out of BMG World in Johannesburg.
- Over 1 000 tons of imported stock landing per month.
- 94 strategically situated branches throughout Africa.
- Vendor Managed Inventory sites (dedicated on-site stockholding).
- International exports.
- Locally empowered distribution chains.

Be PART

24 HR TOLL-FREE EMERGENCY
BRANCH HELPLINE:

0800 022 224

WEBSITE:

www.bmgworld.net



An Invicta Holdings Group Company

BEARINGS • SEALS • POWER TRANSMISSION • DRIVES & MOTORS
MATERIALS HANDLING • FASTENERS & TOOLS • HYDRAULICS
PNEUMATICS • FILTRATION • LUBRICATION • VALVES
TECHNICAL RESOURCES • FIELD SERVICES

B-BBEE 2
EMPOWERING SUPPLIER

ISO 9001	Certified
ISO 14001	Certified
ISO 45001	Certified